



We will be starting soon!

Thanks for joining us





TRI-COUNTY
REGIONAL ENERGY NETWORK

SAN LUIS OBISPO • SANTA BARBARA • VENTURA

Multi-Family Domestic Hot Water

Albert Rooks – WestCoast Efficiency LLC

April 28, 2026



Before We Begin

Here are some quick reminders:

- Call in? Please **share** full name to confirm attendance
- To receive AIA LUs, you **must attend** at least 80% of the training. Attendance will be verified
- Use the "**Chat**" to share questions or comments
- Slides/recording are **shared** after most events and can be found on 3C-REN's on-demand page
- 3C-REN does **not** allow **AI notetakers**, unless used to accommodate a disability

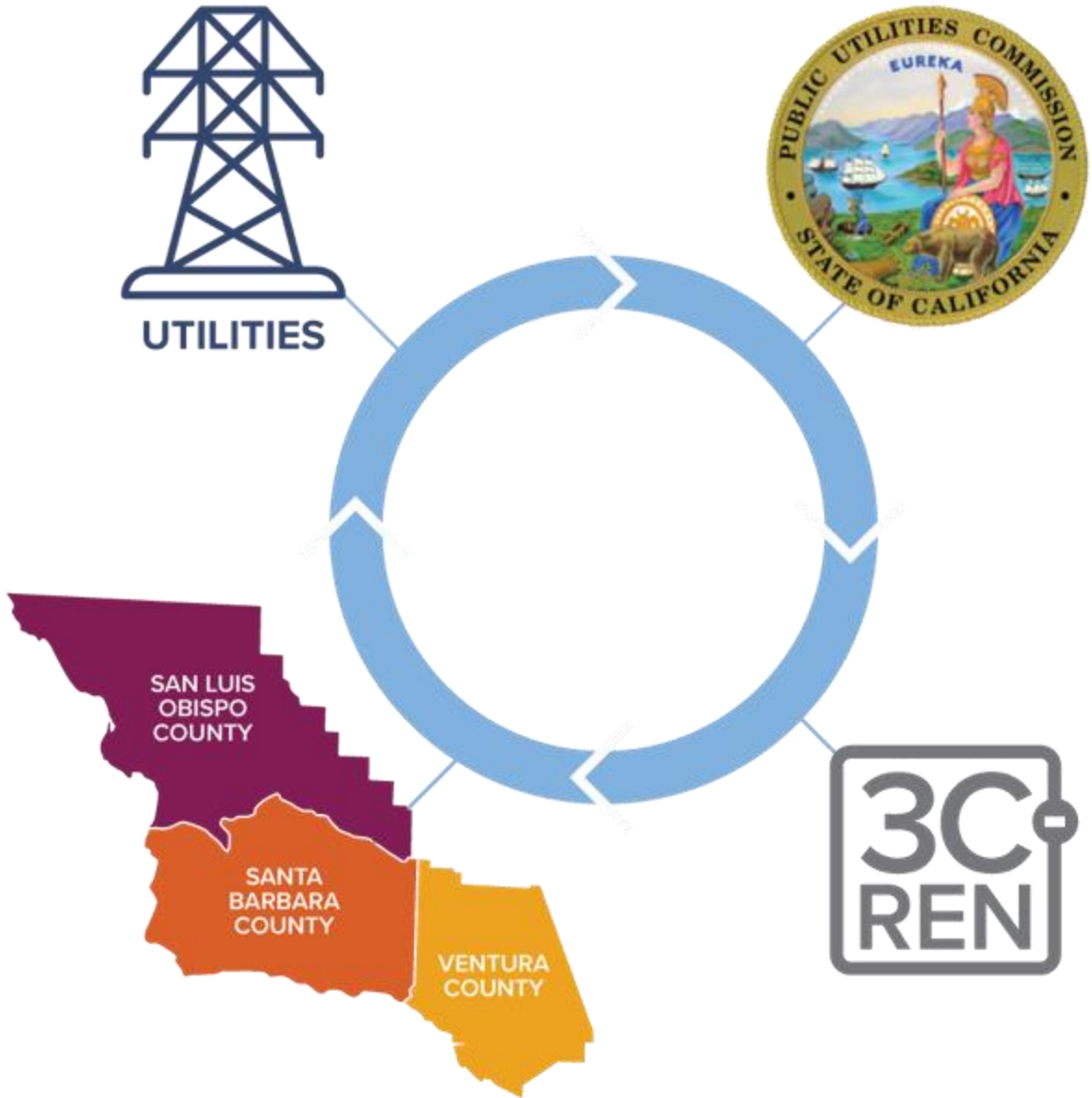

Tri-County Regional Energy Network

3C-REN is a collaboration between the tri-counties

Our programs reduce energy use for a more sustainable, equitable and economically vibrant Central Coast

Our free services are funded via the CPUC, bringing ratepayer dollars back to the region

Our Services

Incentives



HOME ENERGY SAVINGS

3c-ren.org/for-residents
3c-ren.org/multifamily



COMMERCIAL ENERGY SAVINGS

3c-ren.org/commercial

Contractors can enroll at
3c-ren.org/contractors

Training



BUILDING PERFORMANCE TRAINING

3c-ren.org/events
3c-ren.org/building



ENERGY CODE CONNECT

3c-ren.org/code

View past trainings at
3c-ren.org/on-demand

Technical Assistance



AGRICULTURE ENERGY SOLUTIONS

3c-ren.org/agriculture



ENERGY ASSURANCE SERVICES

3c-ren.org/assurance



Albert Rooks

Working on an AHREA committee writing a Guidance on Central Heat Pump Water Heaters (I can't talk about it yet 😞!)

- WestCoast Efficiency LLC
- Small Planet Supply
- WaterDrop Systems

Multi Partner – Multiyear Application Study

- Ken Eklund – Washington State University





The Shift

Moving to heat pump DHW - Is moving
from **Recovery** to **Storage**

The Load

- These are two residential apartment buildings in Seattle WA.
- Normally the gas boiler would be sized to meet the peak flow with very little storage.
- Then there would be the tendency to oversize. Just a little...
- Boilers have high recovery capacity.

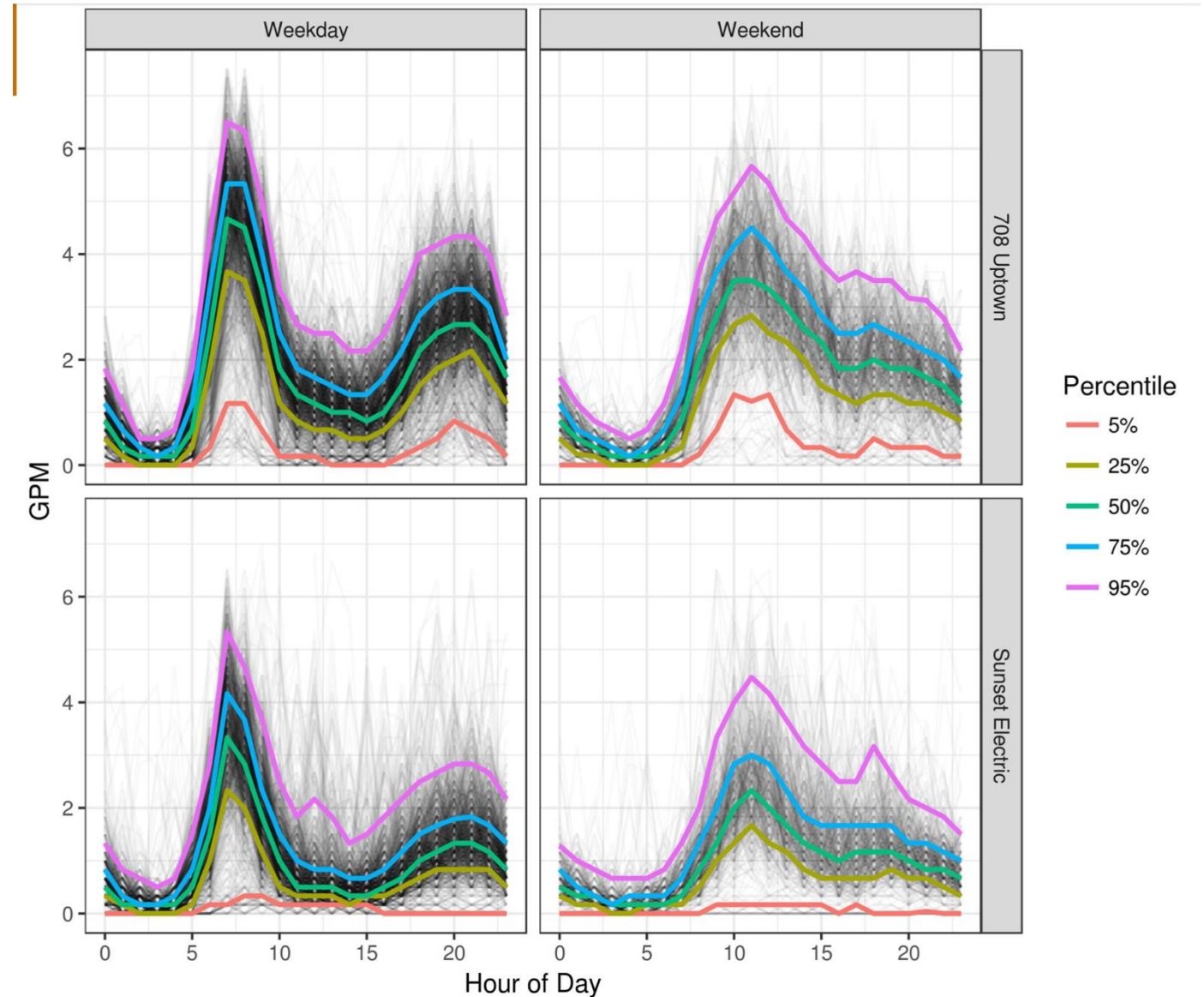

Courtesy of Ecotope

Heat Pump Strategy

- Build storage ahead of draw.
- Size storage to meet the peak loads. In residential buildings this is the morning peak.
- Heat pump capacity is sized to recover the peak in 4 to 8 hours. The recovery rate is developed by load patterns, renewable energy strategy, and equipment utilizations.

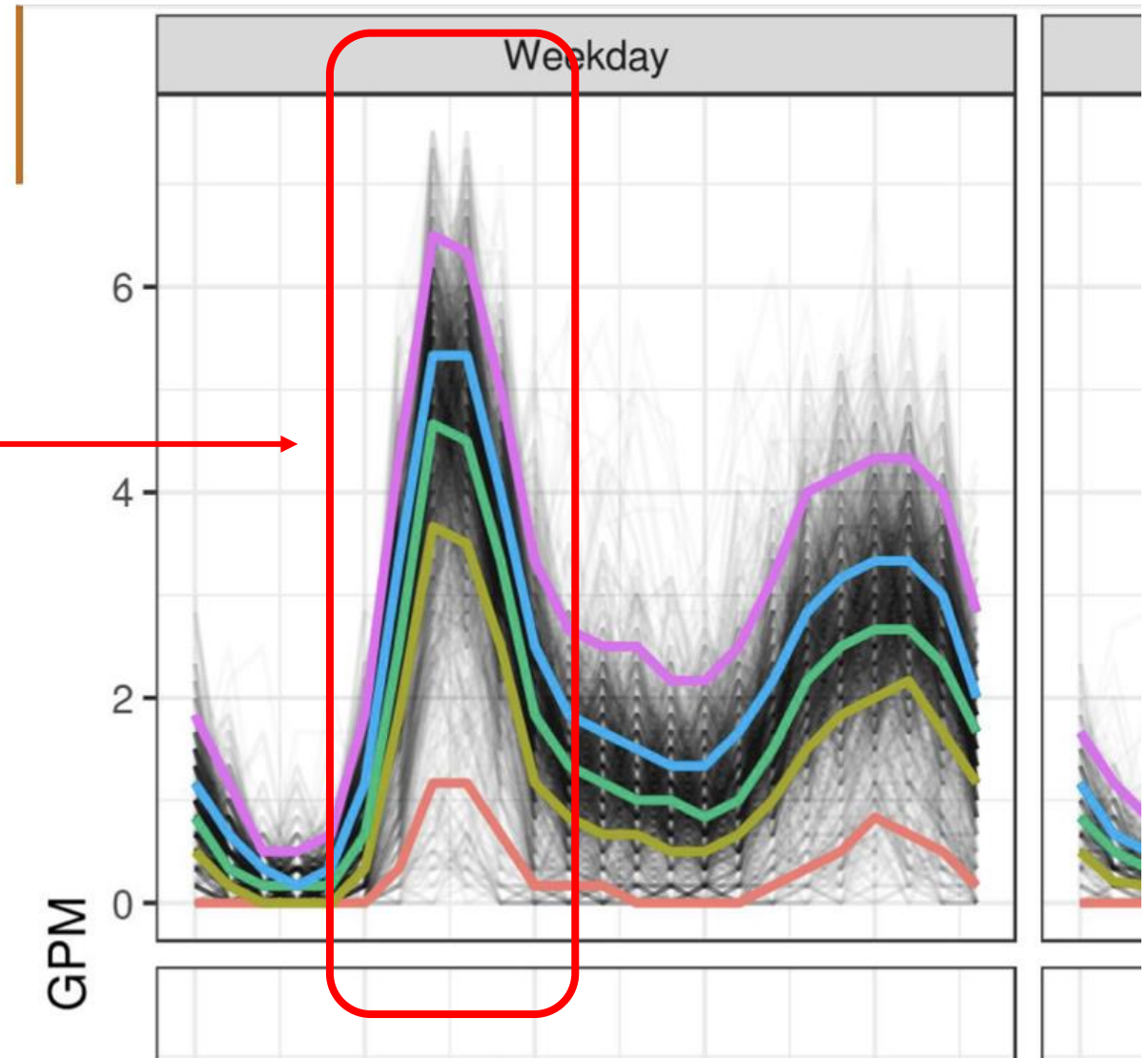

Courtesy of Ecotope

Load Shape

- Morning draw served by storage
- Daytime recovery rebuilds storage.
- Evening Draw takes some storage
- Overnight recovers storage.

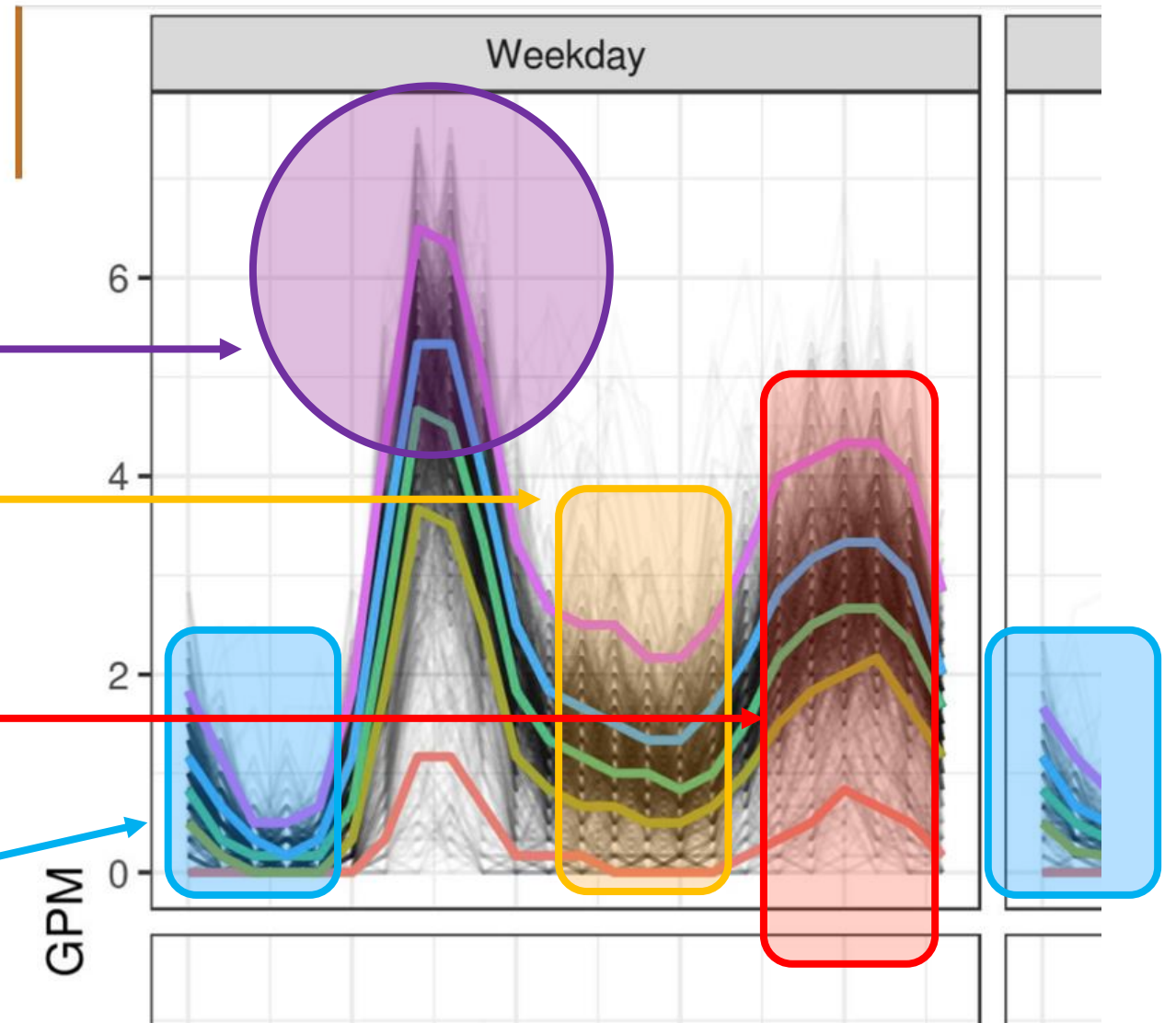

Courtesy of Ecotope

Types Of Heat Pumps

- **Single Pass** – Lift Cold to Hot in one large lift... Or pass through the heat pump.
- **Multipass** – Lift Cold to Hot in multiple passes through the. heat pump. Each pass raises the temperature until full temperature is reached.



Multipass Topics

- Refrigerants
- Compressor Energy
- Storage Temperature
- Air source

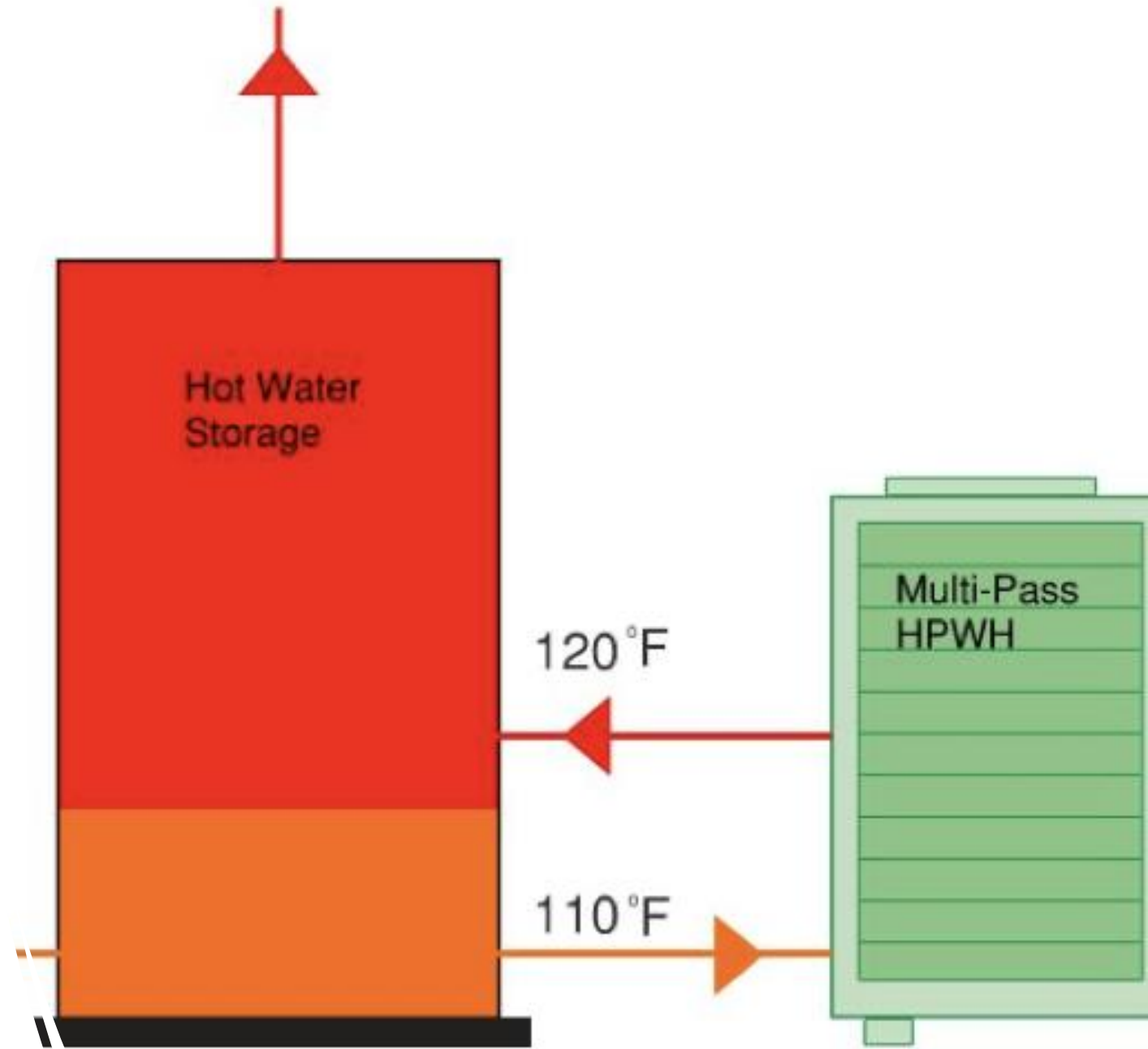

Single Pass Topics

- Refrigerants
- Compressor Energy
- Storage Temperature
- Air source

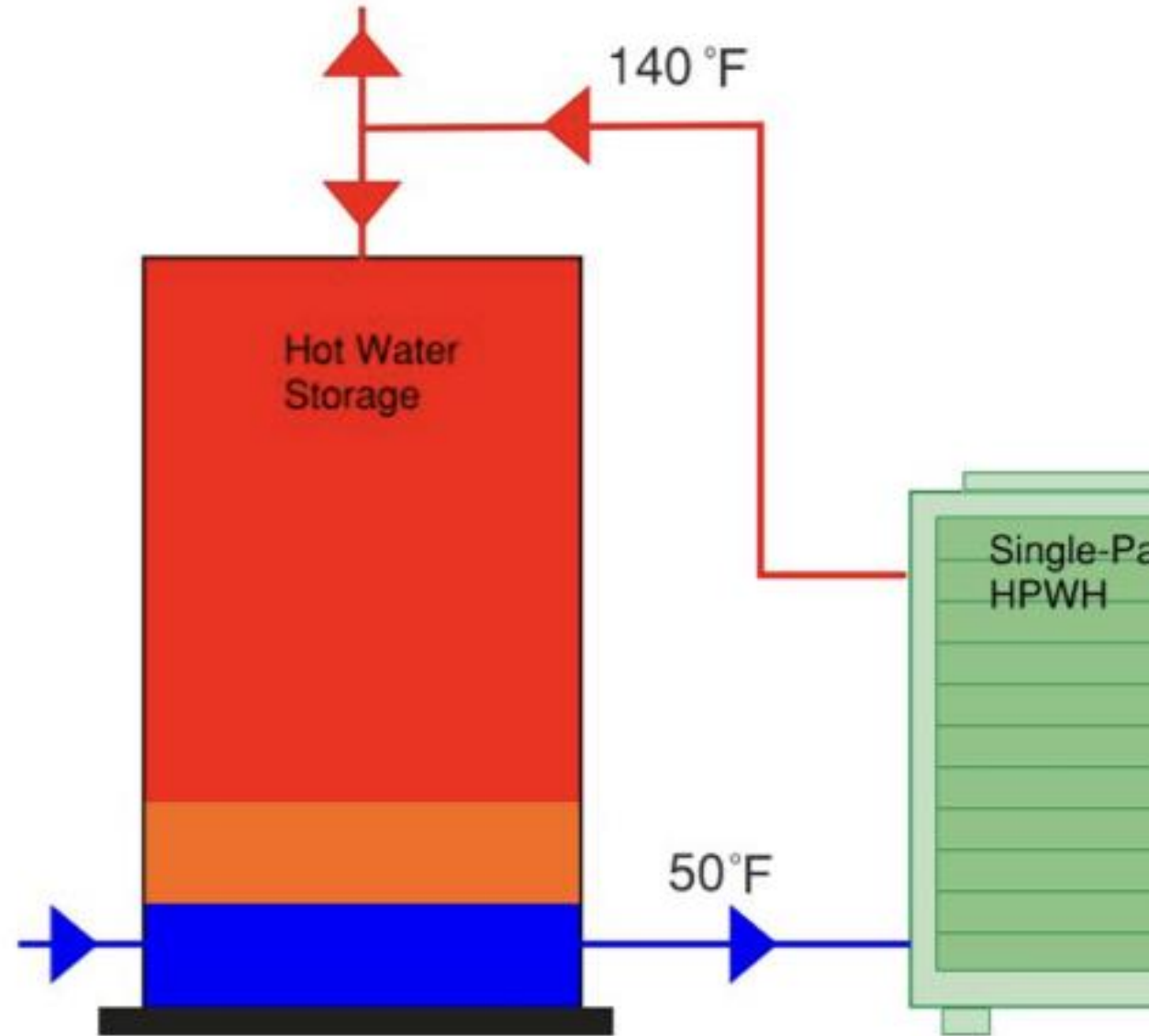



The nature of CO₂

Super Critical – Super Good

Founding Utility Research – Transcritical CO₂



Ken Eklund
Washington State
University

Works in all climates.

No defrost de-rate. Defrost by hot gas bypass.

Stable and reliable leaving water temperature to -14F

No capacity loss thru 5F

WHY WE LIKE CO₂

- Trans-critical nature allows for more efficient heat exchange
- Trans-critical nature allows high output temperatures in all ambient conditions including very cold.
- Trans-critical nature in Single Pass Configuration results in very high COP and capacity

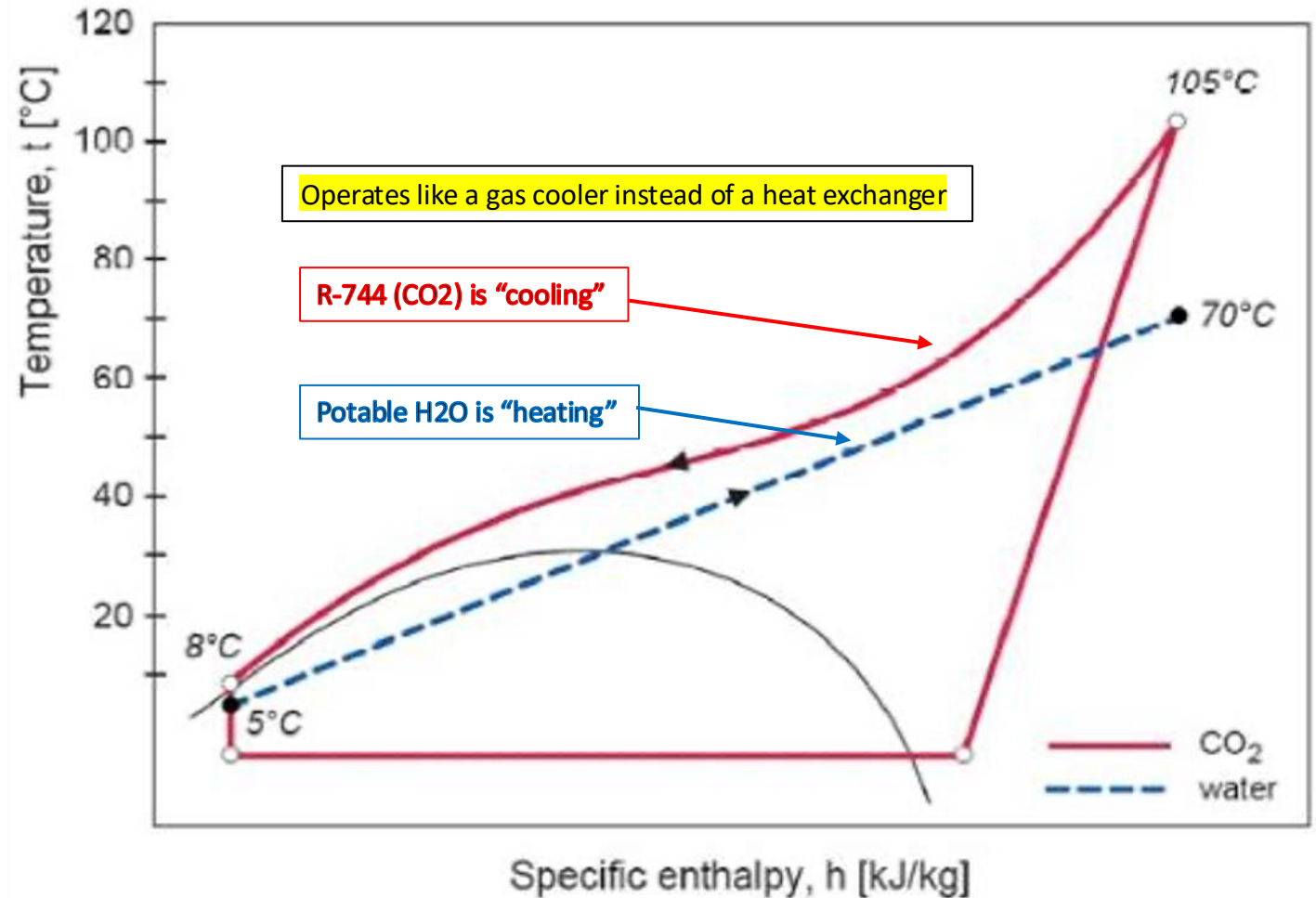



Questions about the Shift to Heat
Pumps or CO2 as a Refrigerant?

Up next – The Single Pass System

Lots of New Heat Pumps are Coming to Market

New HPWH products – Large CO2

- > Laars
- > Mestek/ Transom
- > Copeland CO2 compressor



New HPWH product – Synthetic Low GWP

- > Nyle R513a
- > Colmac R513a





10 Heat Pumps



DECARBONIZATION

Completed 2021 - 1075 West Georgia

ST Vancouver BC



1 BMS Controller

Single Pass System Configuration

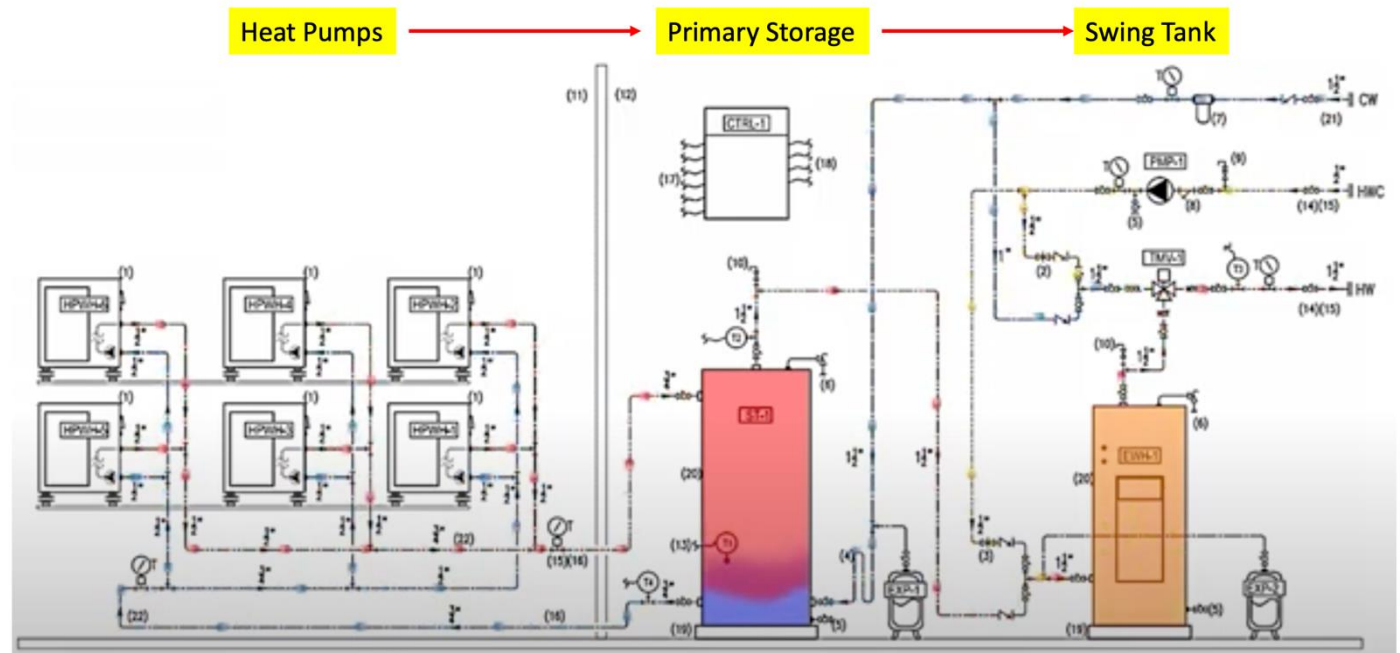

Breaking into Functions

- The primary storage tank(s) are stratified
- The cold municipal water is piped into the bottom of the primary storage tank(s)
- Heat pump(s) take cold water from the bottom of primary storage tank(s) and provide the 100F lift in a single pass.
- The high temperature (150F-170F) is piped to the top of the primary storage tank(s)
- The hot DHW is piped from the top of the primary storage tank to the load.

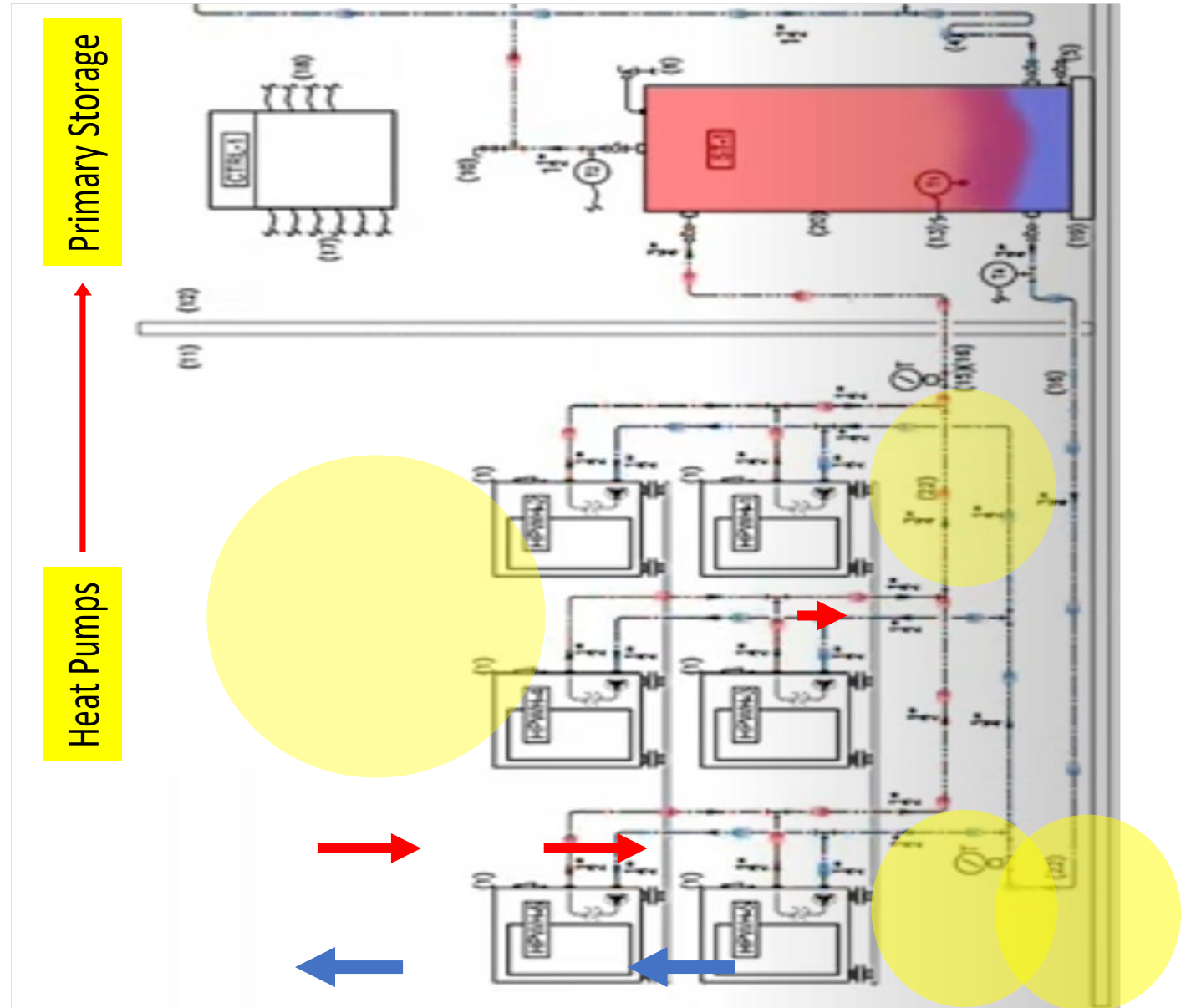

CO2 Needs Cold Water

- CO2 Heat pumps lose both capacity and COP when return temperatures increase.
- As the inlet temperature increases, the delta T decreases.
- The water pump try's to compensate by speeding up the flow.
- The overall capacity is reduced as the entering water temperature increases.



Heating 83 Gallon tank from Cold

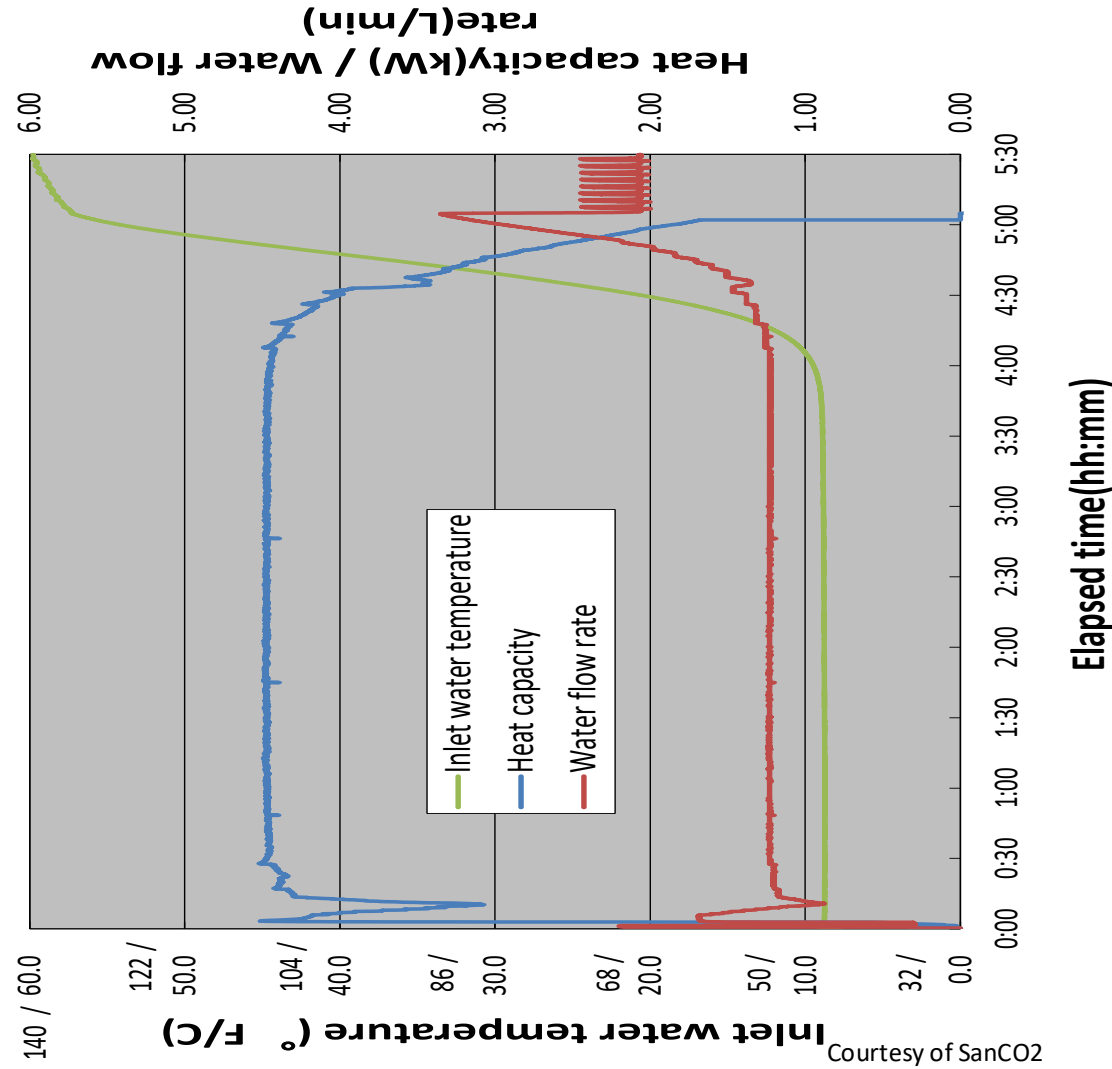

Recirculation losses

Happens overnight as the recirc loop pulls heat from the tank and loses it to the building

**Low
overnight
hot water
use**

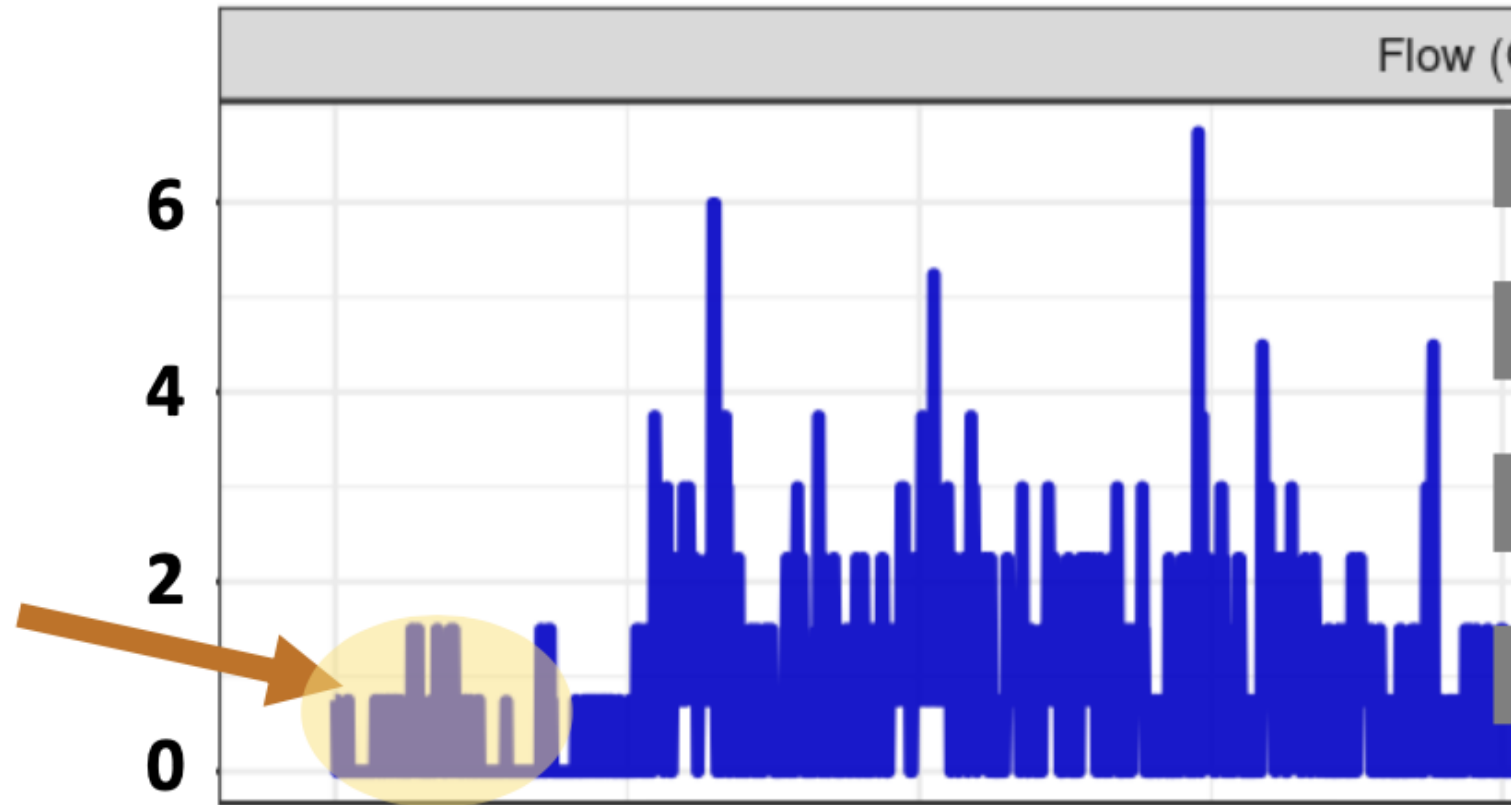

Swing Tank Solution

Place the recirc loop into its own tank

Primary Storage

Heat Pumps

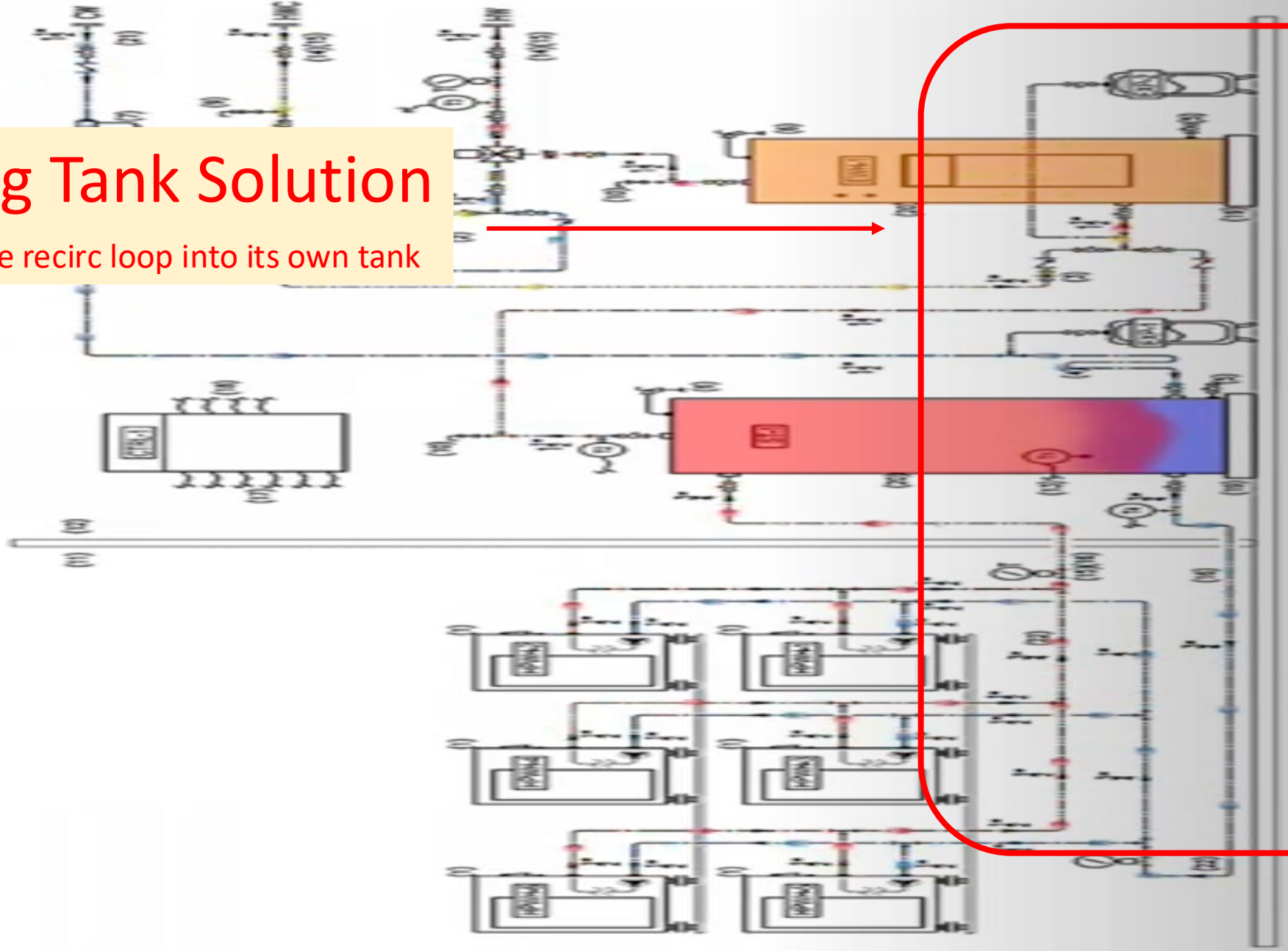

How it works

- Recirculation losses are isolated from primary storage
- Overnight tank temperature can often cool below set point (120F)
- Add electric resistance to provide a short lift back to set point.
- Can also use a multi-pass heat pump.

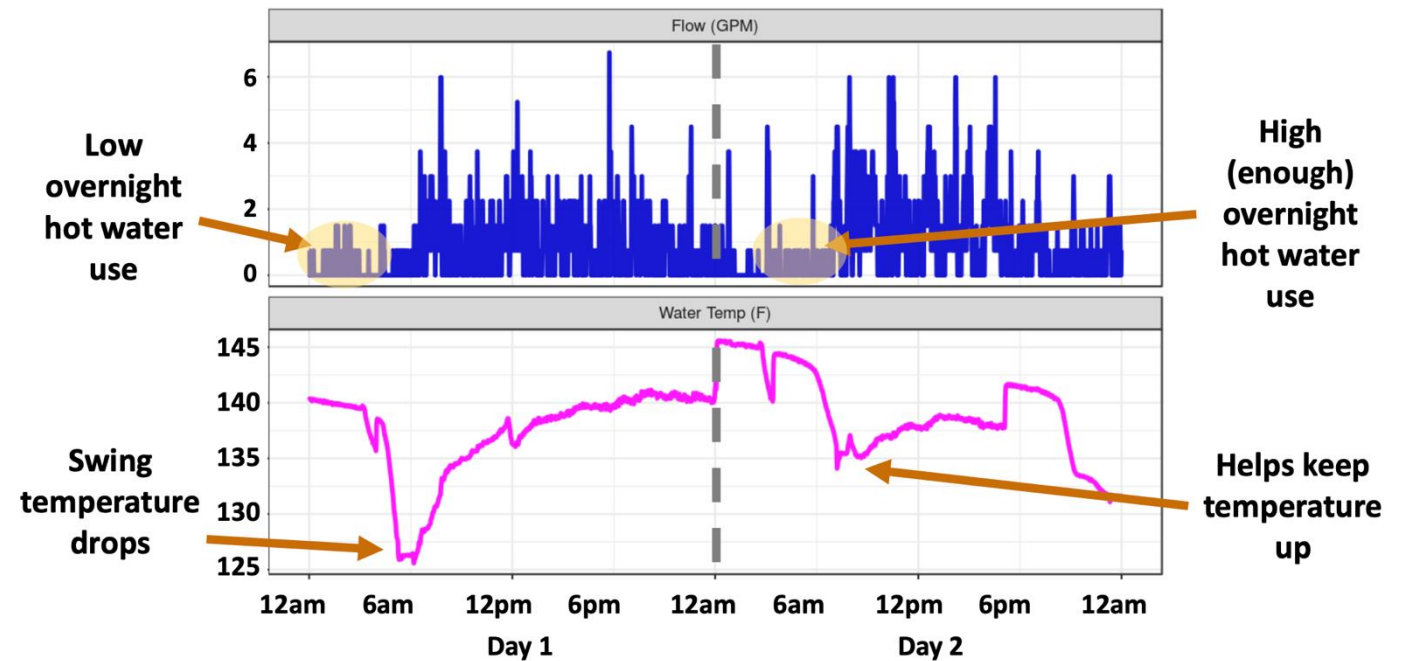

Heat Pumps

Primary Storage

Swing Tank

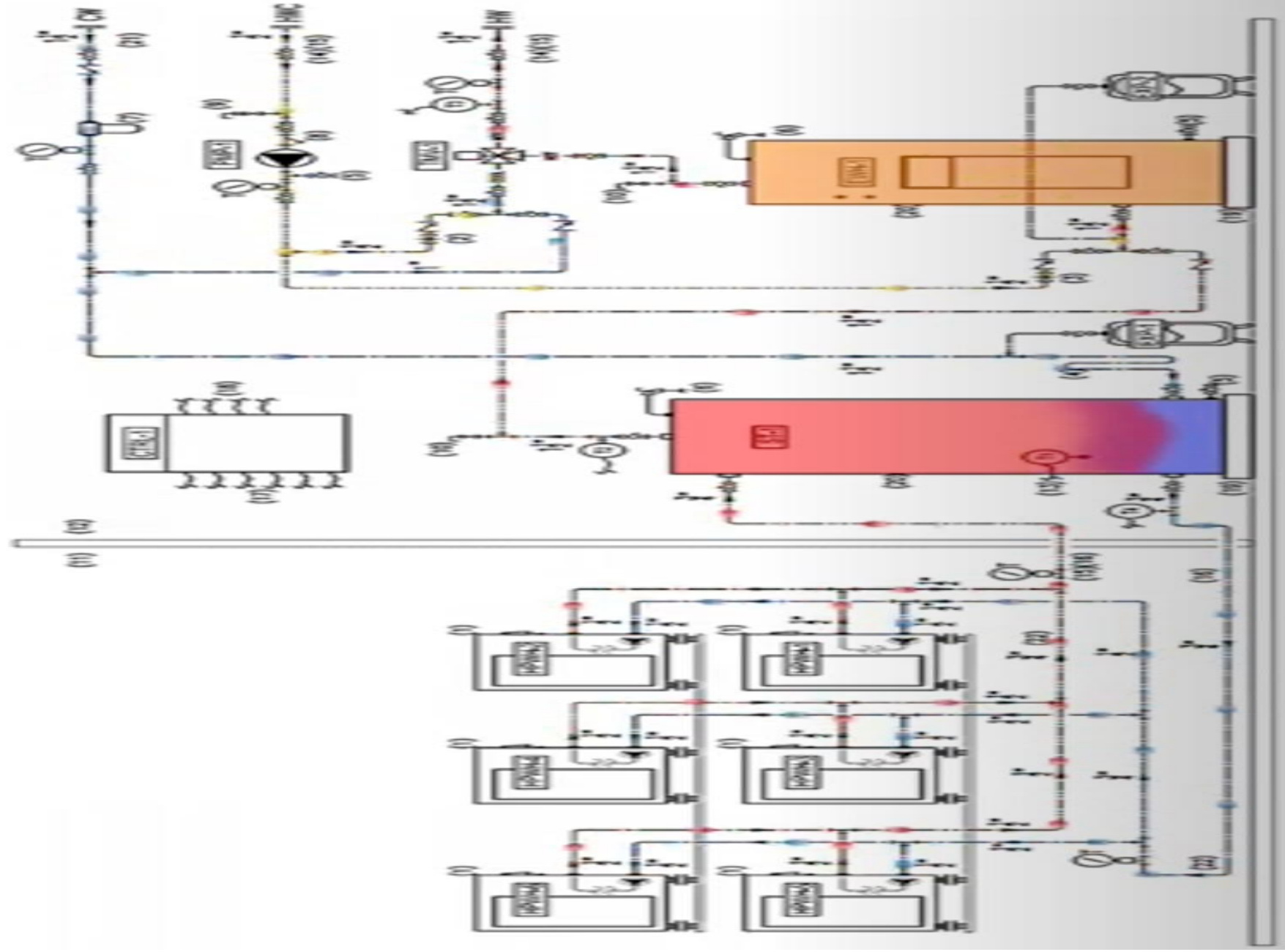

Swing Tank can be both Electric Resistance or a Multipass Heat Pump

Primary HPWH system

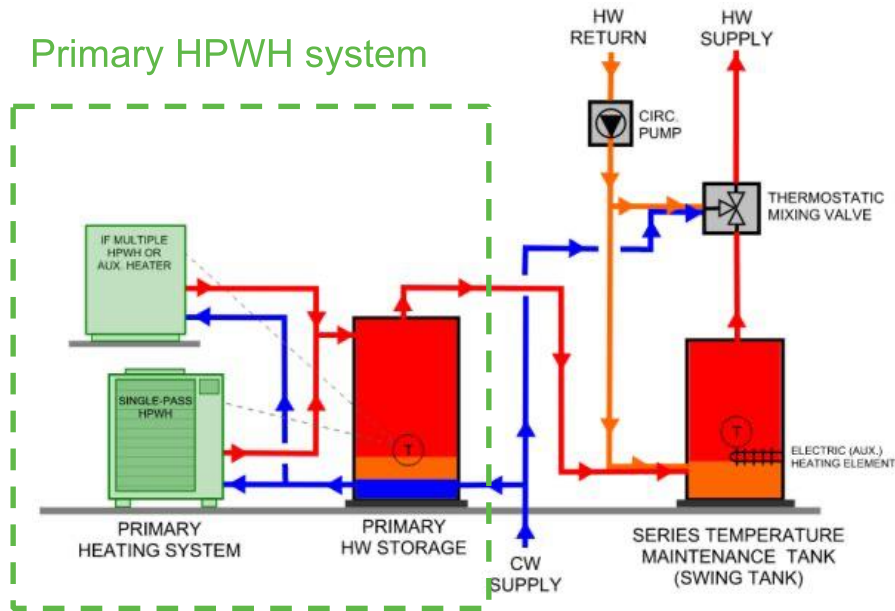

Single-pass primary with electric resistance water heater in series for temperature maintenance system (**HPWH_SPST**)

Primary HPWH system

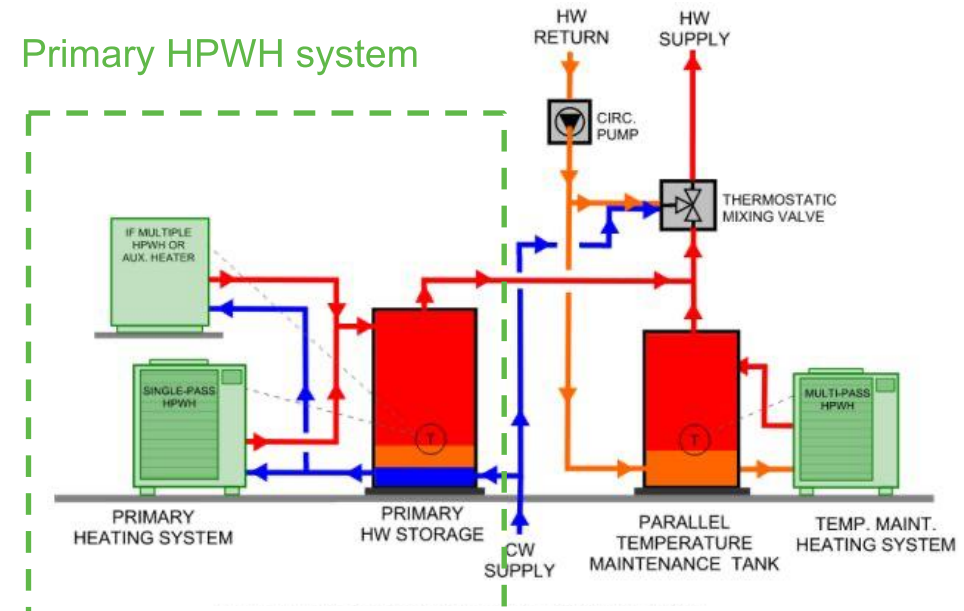

Single-pass primary with multi-pass in parallel for temperature maintenance system (**HPWH_SPwMPTM**)

Source: NEAA, Dec 2022, <https://neea.org/img/documents/advanced-water-heating-specification-v8.0.pdf>

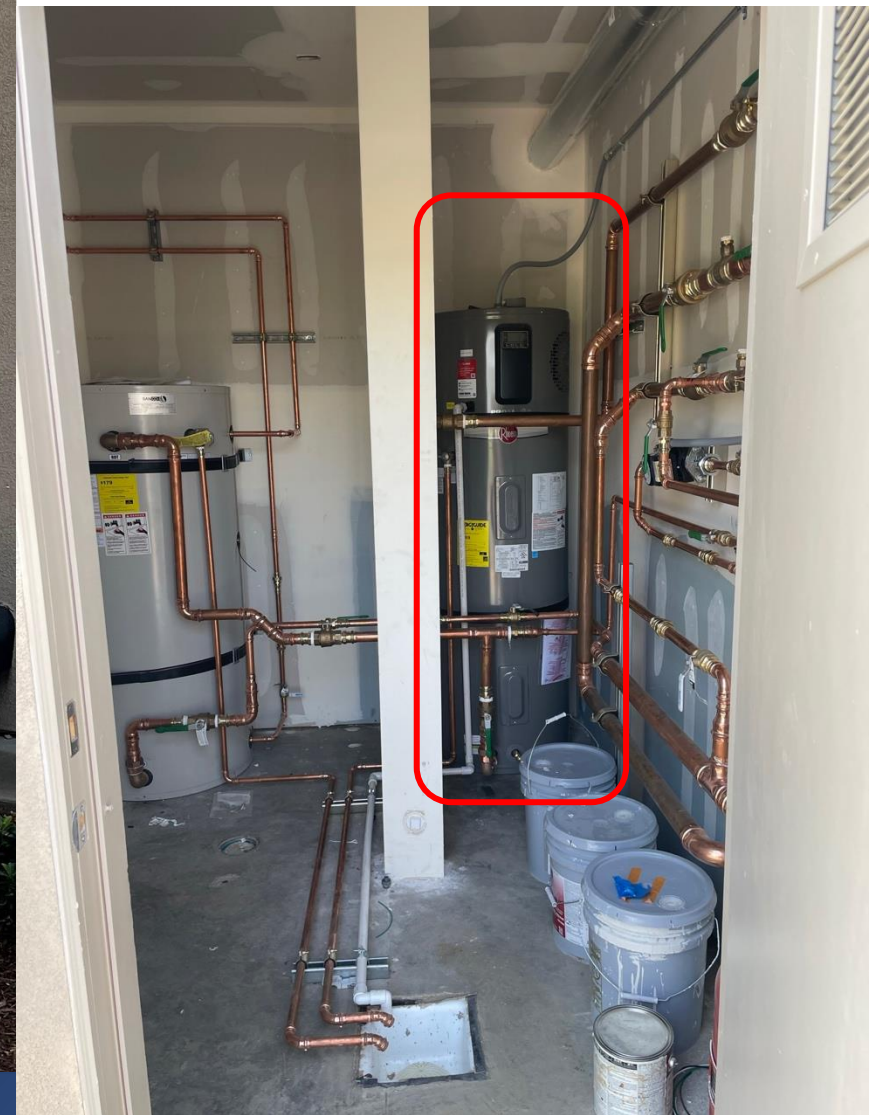

Multipass Swing Tank Delano California

How Utility Driven Load Shift Works

1. Eco Port is installed in the WaterDrop Skid or Droplet
2. Connects to the utility by LTE included in the WaterDrop Controller
3. Listens to the utility commands via Ecoport
 1. Normal
 2. Shed
 3. Critical Peak Event
 4. Grid Emergency
 5. Load Up
 6. Advanced Load Up



Load Shifting Depends on Primary Storage Conditions and the Utility Command

NORMAL – **LOAD UP** - **SHED**

Single Pass

EcoPort Command	Aquastat Fraction	Temperature Setpoints		
		ON-Trigger	OFF-Trigger	HPWH Outlet
Normal	40 %	115 °F	135 °F	145 °F
Load Up	20 %	115 °F	135 °F	145 °F
Shed	80 %	115 °F	135 °F	145 °F

ECOTOPE



Load Shifting Depends on Primary Storage Conditions and the Utility Command

Shed – Avoids the use of heat pumps and recirc tank (where possible) when T-3 is above 125F

Normal – System operates normally – T-2 commands the heat pumps on at 115F

Load Up – Commands the heat pumps on when T-1

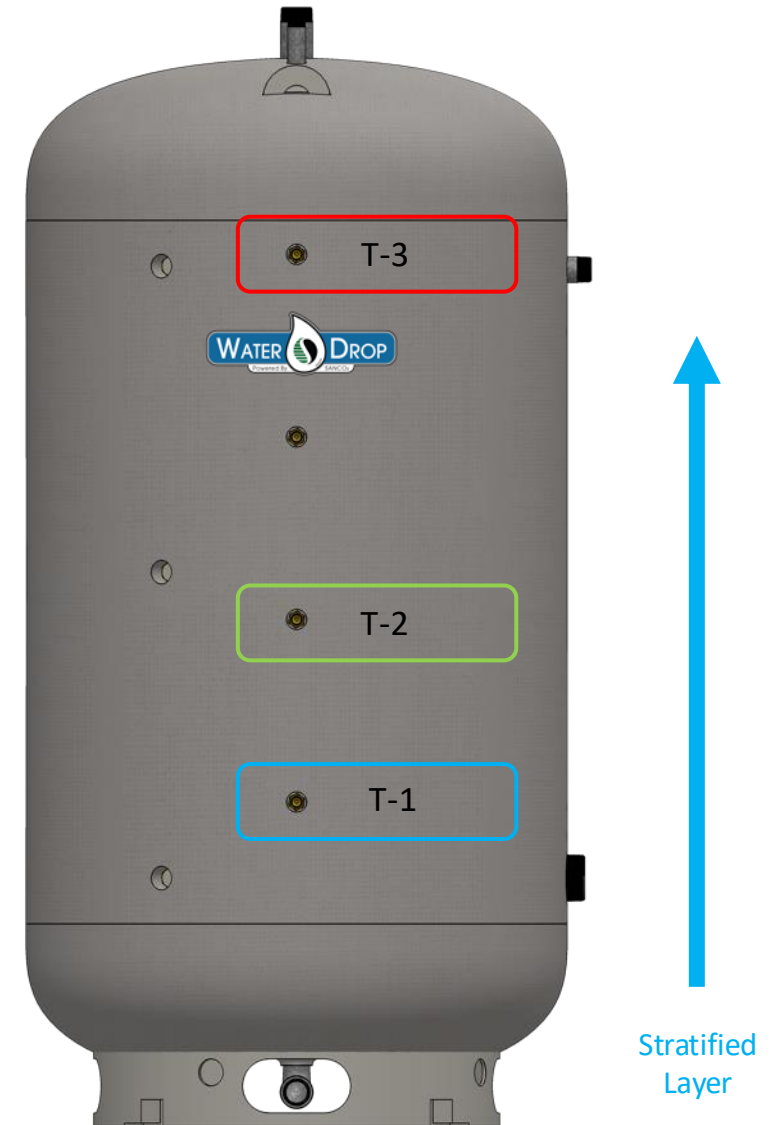

Load Shifting Depends on Primary Storage Conditions and the Utility Command

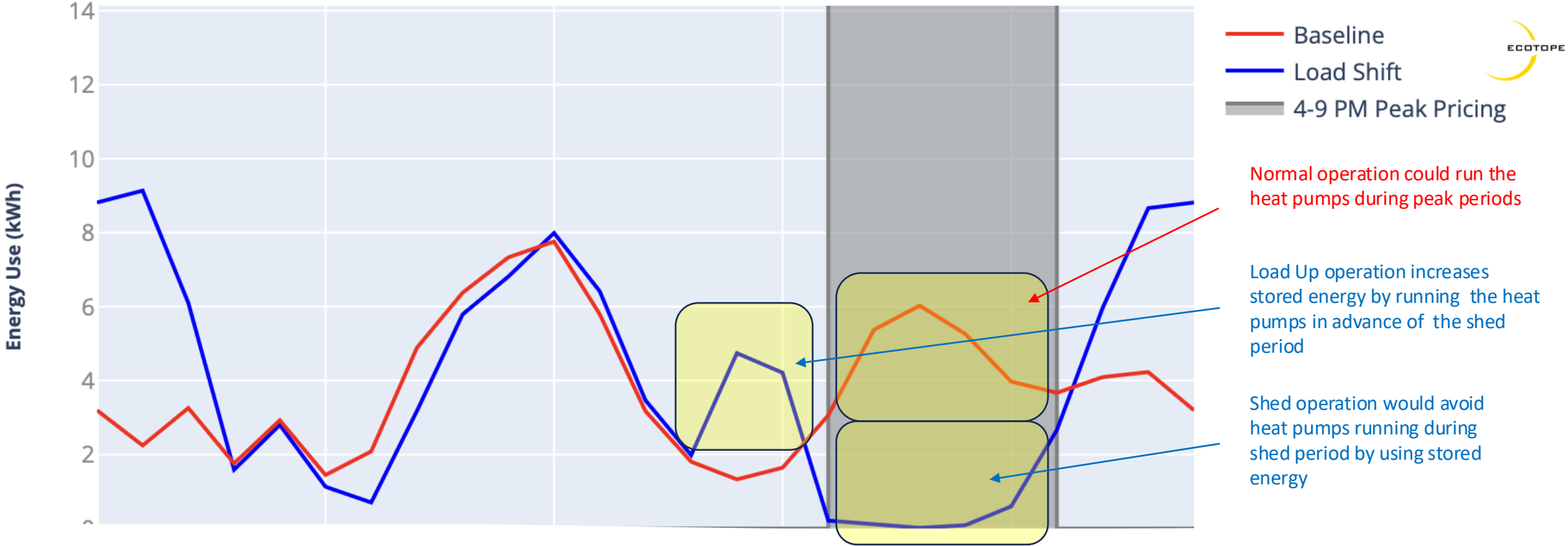



Questions about “The Single Pass System”?

Up next – Sizing a Plant



Sizing a Building

New tools!

The Ecosizer

<https://ecosizer.ecotope.com/sizer/>

ECOSIZER

[Size Your System](#)

[Glossary](#)

[Documentation](#)

[FAQ](#)

[About](#)



Electrifying water heating is a major decarbonization strategy for multifamily buildings.

The Ecosizer is a free tool for sizing central water heating systems based on heat pump water heaters (HPWHs) in multifamily buildings. The tool is designed to support the building industry to adopt HPWHs to improve energy efficiency and reduce greenhouse gas emissions. The Ecosizer is also intended to provide educational information on central HPWH system designs to other stakeholders, for example energy efficiency and building decarbonization advocates, program administrators and implementors, building science researchers, manufacturers, and policy makers.

[MORE INFORMATION](#) ➔

HOW TO USE THIS TOOL

1. Identify weather conditions (cold water temperature and ambient temperature) on the design day, which is usually the coldest day of the year.
2. Select a HPWH technology and identify its temperature setpoint limitations. Consider its potential performance limitations under winter design conditions.
3. Provide input method and values to determine design-day hot water demand.
4. Provide the storage, delivery, and incoming water temperature settings for your system.
5. Select the configuration for the temperature maintenance system.
6. Revise default values for advanced inputs, if needed.
7. Click "Size Your System" to obtain minimum sizing results and the Primary Sizing Curve.
8. Select the actual HPWH heating capacity according to performance characteristics of the selected HPWH technology. Use the Primary Sizing Curve to find the minimum storage volume based on the actual HPWH design-day heating capacity. Alternatively, select a storage volume first and use the Primary Sizing Curve to find the corresponding HPWH output capacity needed to meet the design-day hot water demand.

Occupancy Inputs

ECOSIZER

TOTAL PEOPLE & APARTMENTS		APARTMENT SIZE & OCCUPANCY RATES	
	Number of Apartments	Occupancy Rate [?] ASHRAE Market Rate	Peak Gallons per Day per Person [?] Ecotope Market Rate with Low Flow Fixtures
Studio	50	1.49	1 <input type="range" value="25"/> 49
1 Bedroom	0	1.93	1 <input type="range" value="25"/> 49
2 Bedroom	0	2.39	1 <input type="range" value="25"/> 49
3 Bedroom	0	2.84	1 <input type="range" value="25"/> 49
4 Bedroom	0	3.29	1 <input type="range" value="25"/> 49
5 Bedroom	0	3.74	1 <input type="range" value="25"/> 49

Water Temperatures

Water Temperature

Design Cold

50 °F

Supply

120 °F

Hot Storage

150 °F

Temperature Maintenance System

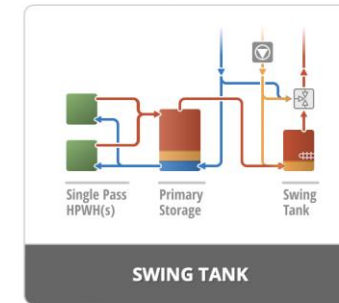

? Primary plant with a temperature maintenance plant in series

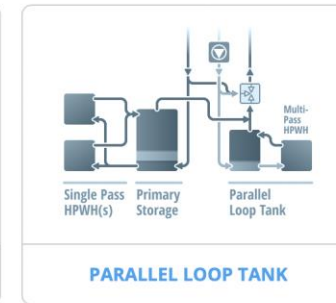

? Primary plant with a temperature maintenance plant in parallel

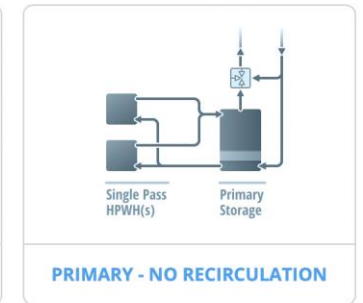

? Just the primary plant without a temperature maintenance load

Results



Results

The graph below represents the trade off between storage volume and heating capacity. The Ecosizer method result is the green curve in the graph. The system sized from user inputs is the blue diamond. Users should pick any point above the green curve to determine their system sizing.

Use the slider bar below the plot to select a different size system.

Primary Sizing Curve

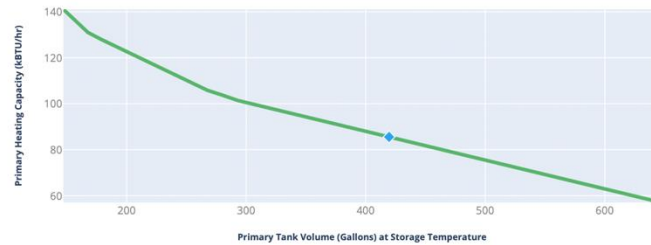

Primary System Size, Storage: 419.54 Gal, Capacity: 85.5 kBtu/hr, Compressor Runtime: 16.0 hr



RECOMMENDATIONS

The recommended minimum heating capacity shown below is the **minimum** needed average output capacity of the selected equipment at the design cold air temperature in your climate zone. Note that you must also account for manufacturer specific defrost penalty.

Primary Storage



Tank Volume ⓘ
420.00 Gallons

Heating Capacity ⓘ
85.50 kBtu/hr



Heat Pump Capacity

Swing Tank



Swing Tank Volume ⓘ
120 - 300 Gallons



Swing Resistance Element ⓘ
8.7 kW · 29.9 kBtu/hr

CA Title 24 Swing Tank Volume ⓘ
288 Gallons

THIS SYSTEM WAS SIZED FOR

Occupancy
74.5 People

Apartments
50.0 Units

Daily Hot Water Usage
25.0 Gallons per Day per Person

Total Hot Water
1,862.50 Gallons per Day

Recirculation Loop
Heat Loss
100.0 Watts per Apartment

Details

SAVE RESULTS TO PDF

SEND US YOUR FEEDBACK

Hot Water Simulation

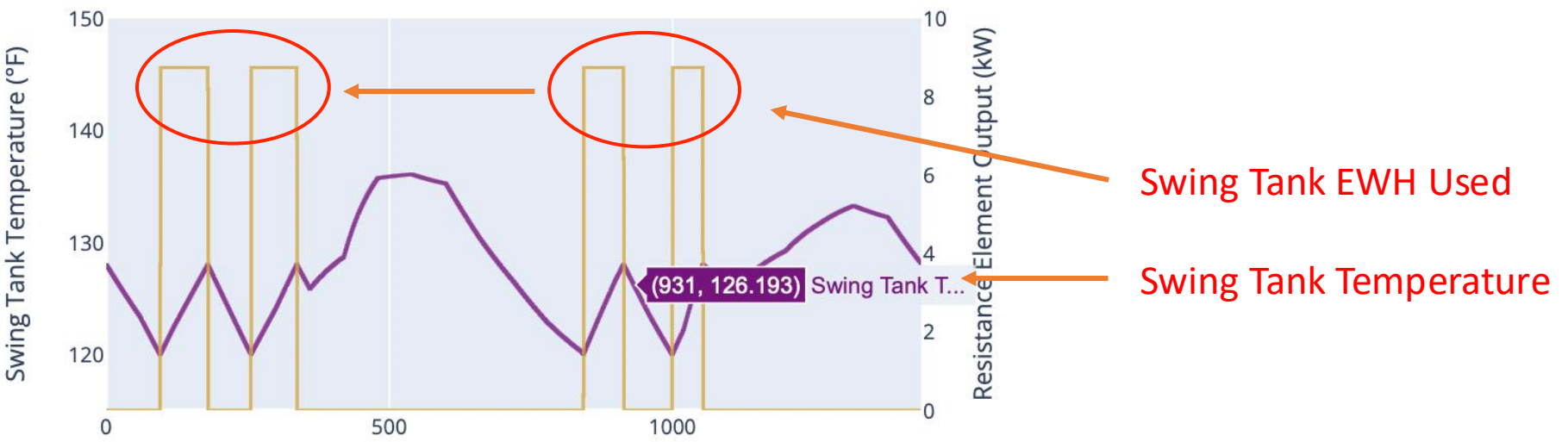

Swing Tank EWH Used

Swing Tank Temperature

Load Shifting & Demand Response

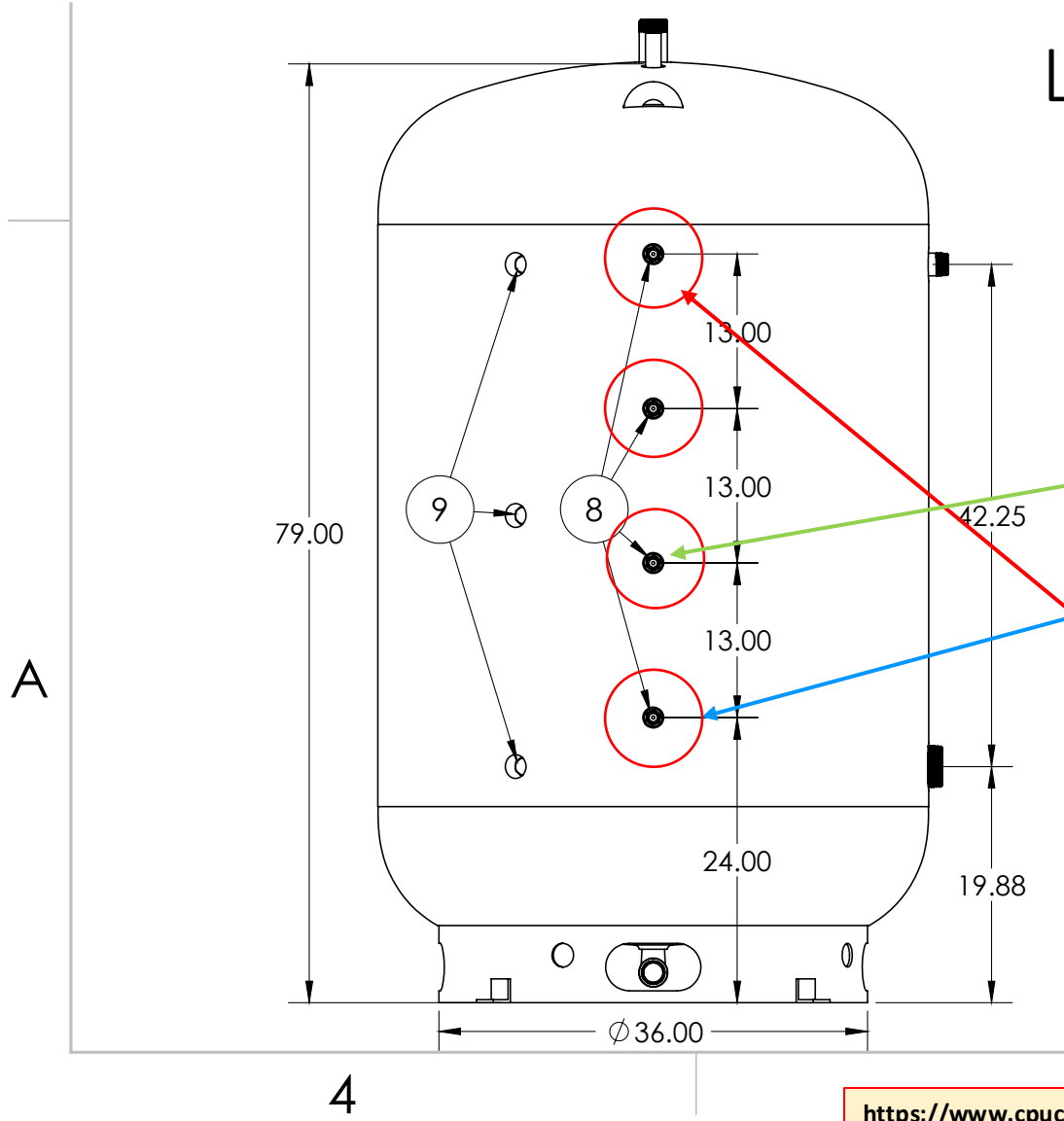

Single Pass

EcoPort Command [?] Aquastat Fraction [?] Temperature Setpoints

EcoPort Command [?]	Aquastat Fraction [?]	ON-Trigger [?]	OFF-Trigger [?]	HPWH Outlet [?]
Normal [?]	40 %	115 °F	135 °F	145 °F
Load Up [?]	10 %	115 °F	135 °F	145 °F
Shed [?]	85 %	115 °F	135 °F	145 °F



<https://www.cpuc.ca.gov/industries-and-topics/electrical-energy/demand-side-management/self-generation-incentive-program>



Questions about “Sizing a Plant”?

Up next – California Codes

Central HPWH System Approach

System performance and applications vary by:

- Primary HPWH equipment types
 - Single-pass vs. Multi-pass
 - Refrigerant type
 - Capacity
- Temperature maintenance system (TMS) for maintaining hot water temperature in recirculation loop
 - Decoupled from primary system
 - Direct return to primary system

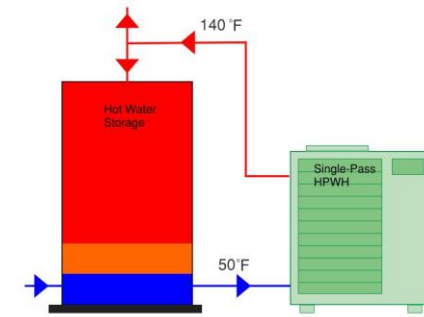

Single-Pass

Heats up water to working temperature in single pass

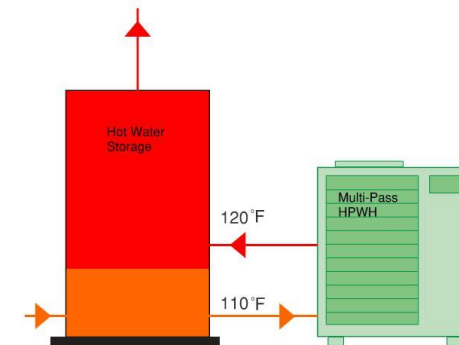

Multi-Pass

Heats up water to working temperature in multi pass

Source: TRC CASE Proposal - Central Heat Pump Water Heater Code Clean-up JingJuan “Dove” Feng

Recirculation Loop Decoupled from Primary System

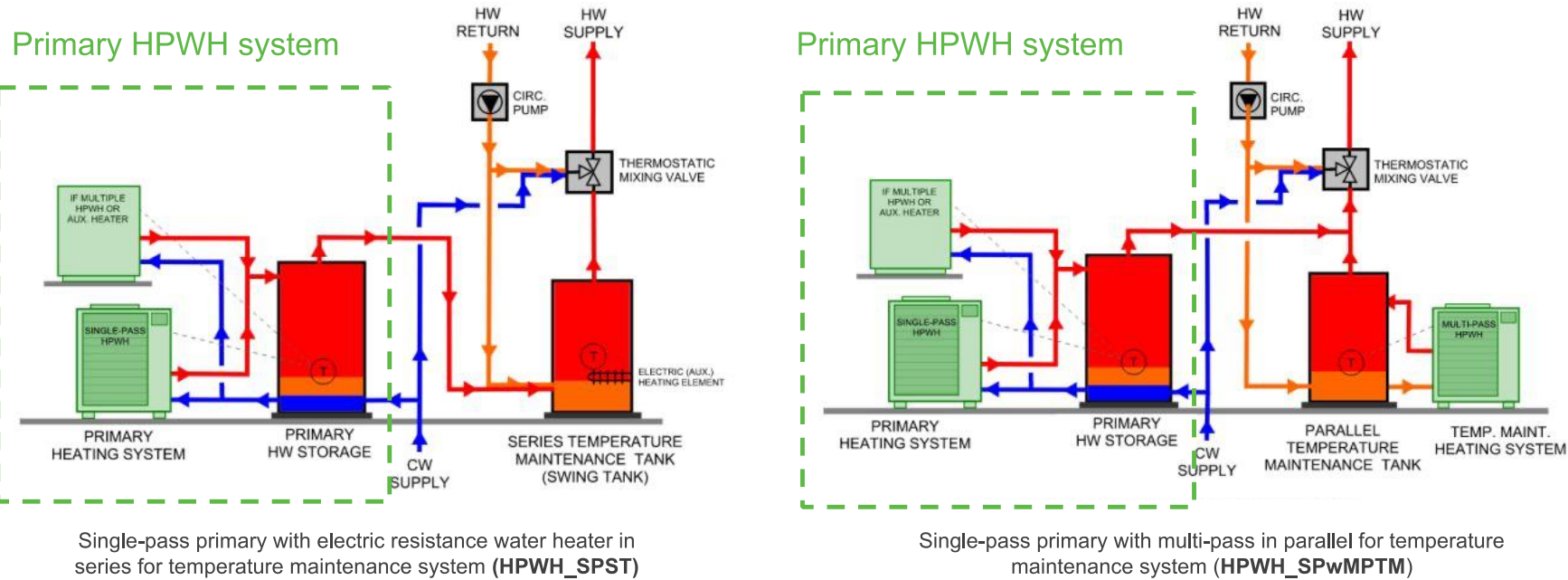

Source: NEAA, Dec 2022, <https://neea.org/img/documents/advanced-water-heating-specification-v8.0.pdf>

Source: TRC CASE Proposal - Central Heat Pump Water Heater Code Clean-up JingJuan “Dove” Feng

Temperature Maintenance System Return to Primary Configurations

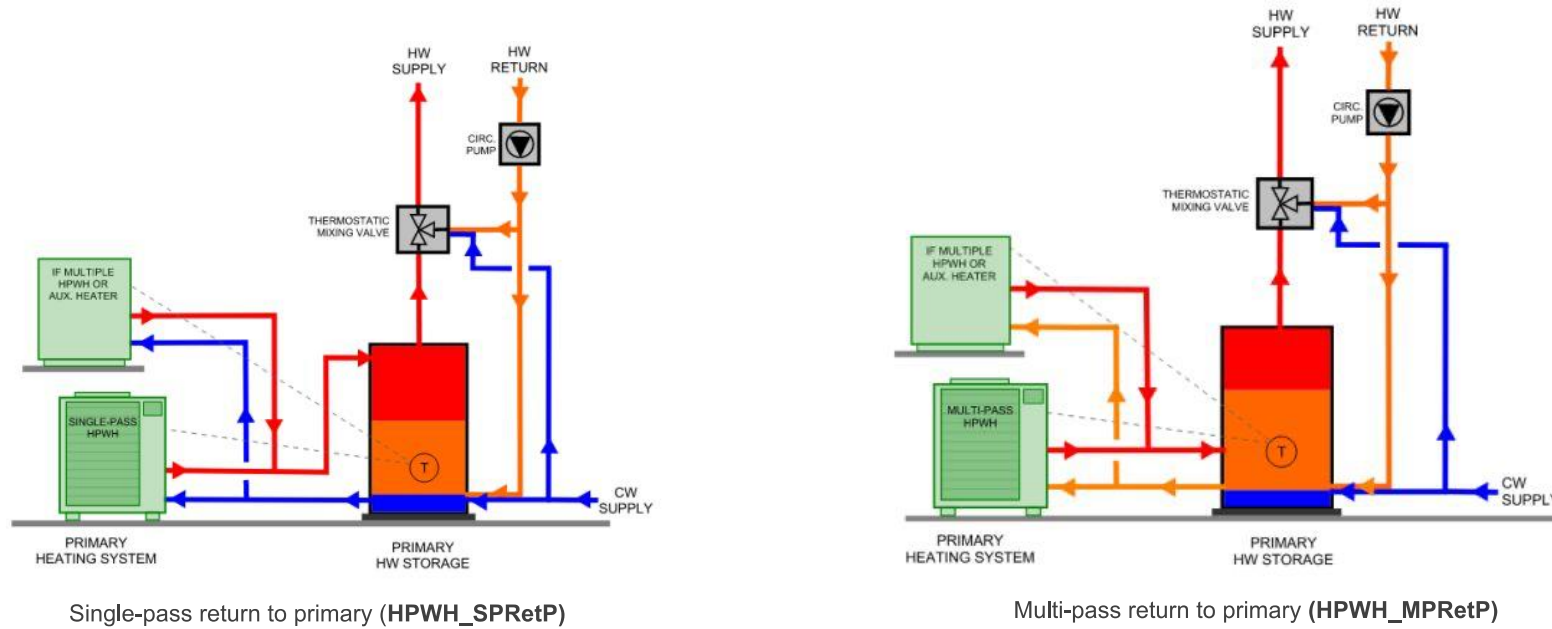

Source: NEAA, Dec 2022, <https://neea.org/img/documents/advanced-water-heating-specification-v8.0.pdf>

Source: TRC CASE Proposal - Central Heat Pump Water Heater Code Clean-up JingJuan “Dove” Feng

Central HPWH System Energy Performance

Example: Annual System COP for Climate Zone 12

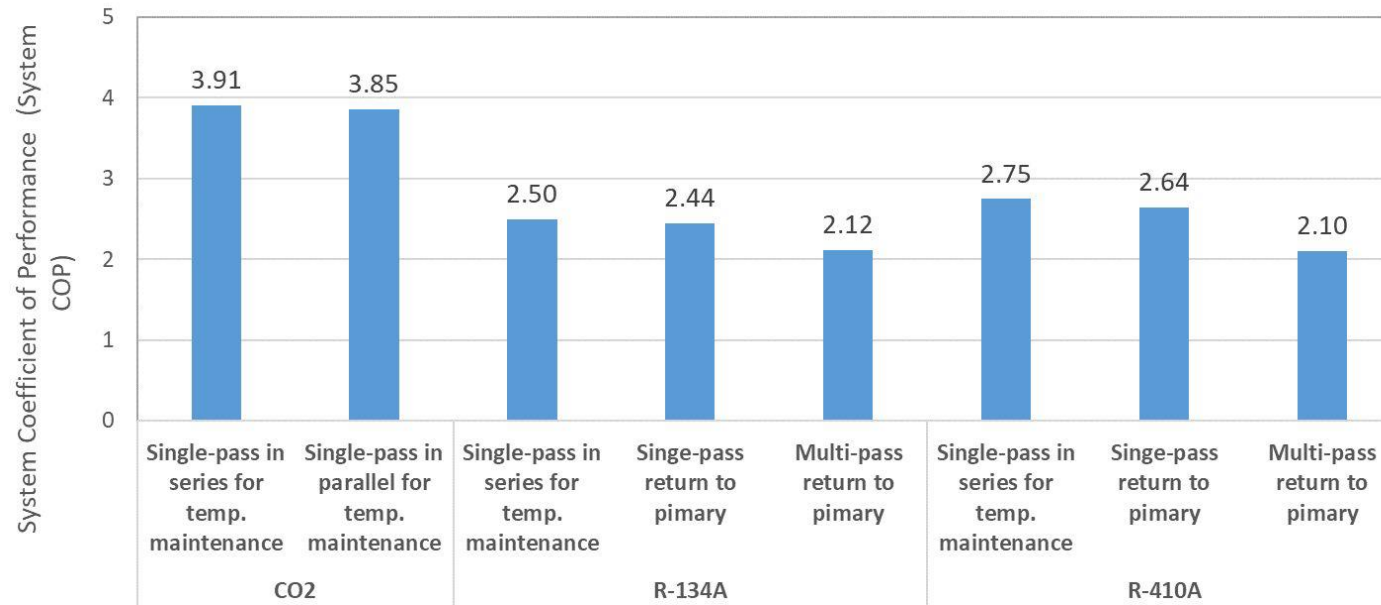

NEEA Tier 3 System COP = 2.5 for most CA climate zones

Source: the DHW CASE Team

Source: TRC CASE Proposal - Central Heat Pump Water Heater Code Clean-up JingJuan "Dove" Feng

Current Code Requirements

Existing requirements in Title 24, Part 6 **Section 170.2(d)2**

- Allows both single-pass and multi-pass primary equipment
- Requires recirculation loop decoupled from primary HPWH systems
- Plumbing configurations to ensure stratification in primary tanks
- Control requirements to achieve minimal efficiency
- Design documentation of specified operating conditions of the system according to Joint Appendix 14.4

Performance Requirements: Joint Appendix 14

- Qualification requirements for a performance pathway for central HPWH
- Includes product performance testing requirements, as well as design documentation requirements

Source: 2022 Building Efficiency Standards for Residential and Nonresidential Buildings

Source: TRC CASE Proposal - Central Heat Pump Water Heater Code Clean-up JingJuan “Dove” Feng

Draft Proposed Code Change Language

- Updates prescriptive requirements in Section 170.2(d)2 to include two compliance paths:
 - (a) **Single-pass primary HPWH meeting prescriptive requirements.** Summary of revisions highlighted in red:
~~Either single-pass and multi-pass primary equipment~~ → Single-pass primary HPWH equipment
 - Requires recirculation loop decoupled from primary HPWH systems
 - Plumbing configurations to ensure stratification in primary tanks
 - Control requirements to achieve minimal efficiency
 - Requires heat pump compressor cut-off to be 40° F or lower
 - Design documentation of specified operating conditions of the system according to Joint Appendix 14.4
 - (b) **A system that meets requirement of NEEA Advanced Water Heating Specification for commercial HPWH system Tier 3 or higher.**

Source: TRC CASE Proposal - Central Heat Pump Water Heater Code Clean-up JingJuan “Dove” Feng

NEEA CHPWH Qualified Products List

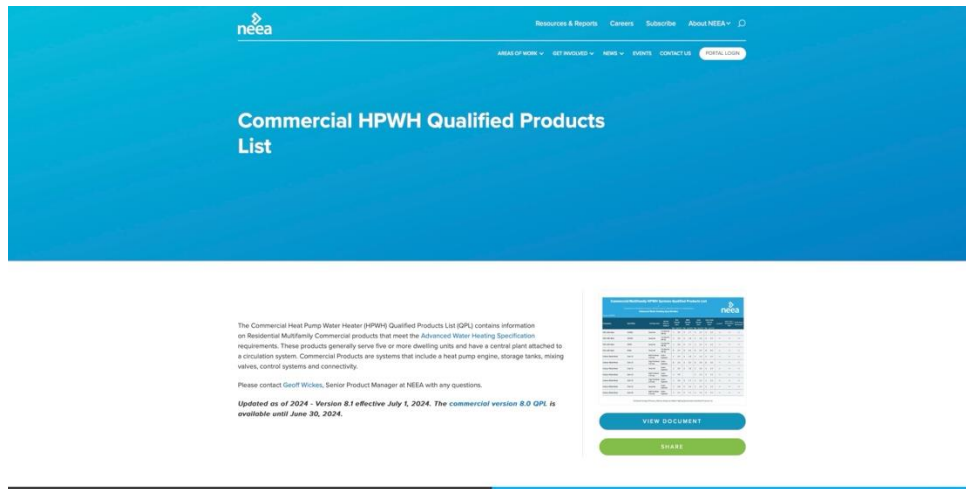

Rheem	HPHD-60HNU-201 (HORIZONTAL)	Multi Pass Return to Primary	Custom Engineered	1	2.2	1	1.7	1	1.5	1	1.4	No	No	No
Rheem	HPHD-60HNU-201 (VERTICAL)	Multi Pass Return to Primary	Custom Engineered	1	2.2	1	1.7	1	1.5	1	1.4	No	No	No
Small Planet Supply	Small Planet Supply SanCO2 System	Swing Tank	Fully Specified Built-Up	2	2.7	3	2.6	3	2.4	2	2.0	No	No	No
Small Planet Supply	WD1S-60-300-119-09	Swing Tank	Full Packaged Skid-Mounted	2	2.7	3	2.6	3	2.4	2	2.0	No	No	No
Small Planet Supply	WD1S-75-430-119-09	Swing Tank	Full Packaged Skid-Mounted	2	2.7	3	2.6	3	2.4	2	2.0	No	No	No
Small Planet Supply	WD1T-90-500-119-12	Swing Tank	Full Packaged Skid-Mounted	2	2.7	3	2.6	3	2.4	2	2.0	No	No	No
Small Planet Supply	WD2S-120-650-119-12	Swing Tank	Full Packaged Skid-Mounted	2	2.7	3	2.6	3	2.4	2	2.0	No	No	No
Small Planet Supply	WD2S-150-800-200	Swing Tank	Full Packaged Skid-Mounted	2	2.7	3	2.6	3	2.4	2	2.0	No	No	No
Small Planet Supply	WD2S-180-1000-200	Swing Tank	Full Packaged Skid-Mounted	2	2.7	3	2.6	3	2.4	2	2.0	No	No	No
Steffes Origin with Nyle	C125A	Swing Tank	Full Packaged Skid-Mounted					1	1.3	1	1.3	Yes	No	Yes
Steffes Origin with Nyle	C185A	Swing Tank	Full Packaged Skid-Mounted	1	1.8			1	1.4	1	1.3	Yes	No	Yes

<https://neea.org/resources/commercial-hpwh-qualified-products-list>

Engineering Resources

Drop-In • Plug & Play • Central Plants for Domestic Hot Water

California Title 24 CBECC Modeling

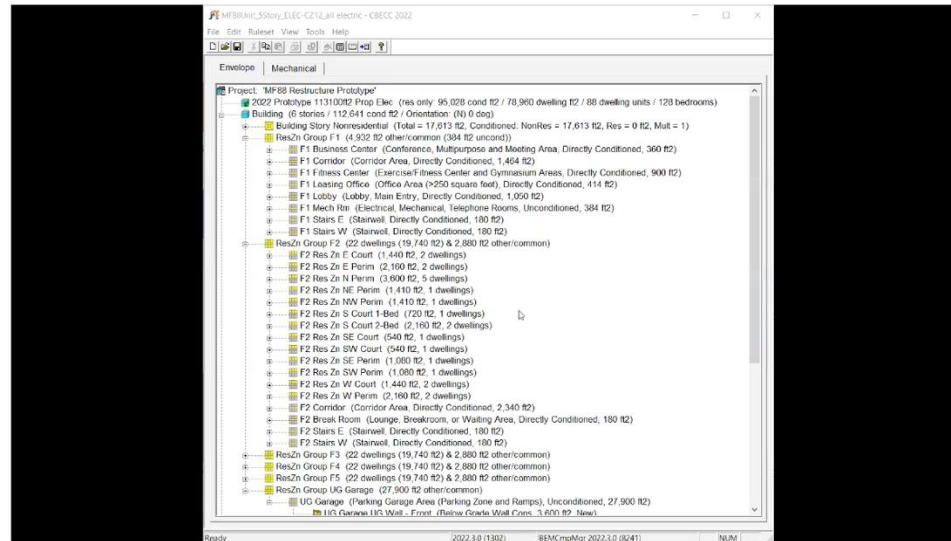

A quick demonstration on how to enter a WaterDrop System into California Title 24 software using CBECC modeling software.

Proposed Code Change

System Configurations		Prescriptive Compliance Pathway		
		2022	2025	
			Primary path	Alternative path
Single-Pass Primary	with HW Circulation Returned to Primary Storage	No	No	NEEA AWHS Commercial HPWH Tier 3 or higher
	with Series Temperature Maintenance Tank System (Swing Tank)	Yes	Yes	
	with Parallel Temperature Maintenance Tank System with multi-pass HPWH	Yes	Yes	
Multi-Pass Primary	with HW Circulation Returned to Primary Storage	No	No	
	with Series or Parallel Temperature Maintenance Tank System (Swing Tank)	Yes	No	

All configurations can use the performance pathway

Source: TRC CASE Proposal - Central Heat Pump Water Heater Code Clean-up JingJuan “Dove” Feng



Questions about “California Codes”?

Up next – Types of CHPWH Deliveries



Site built plants have been successful but...

Space and complexity can be reduced into a package

Major Components of Laars Heat Pump System



Heat Pump



I/O Panel



Storage Tanks



Temperature Maintenance Tank



Diffuser

- Heat Pump pulls heat from air to transfer to domestic water. Main heat source for DHW system.
- I/O panel allows for remote installation of tanks far from the heat pump, neatly houses wiring.
- Storage tanks hold required hot water to meet daily demand, sized for daily load vs. peak load.
- Temperature maintenance tanks provide hot water for recirculation loop needs. Minimizes likelihood of stored hot water to be depleted.



Diffusers are placed into the storage tanks to help maintain temperature stratification. Tank temperature stratification helps to maximize installed efficiency.

Packaged would be faster, better, and with less risk





Deliveries

Parts, Pumps and Skids

Eklund Innovation Center

Factory Assembled Plug & Play



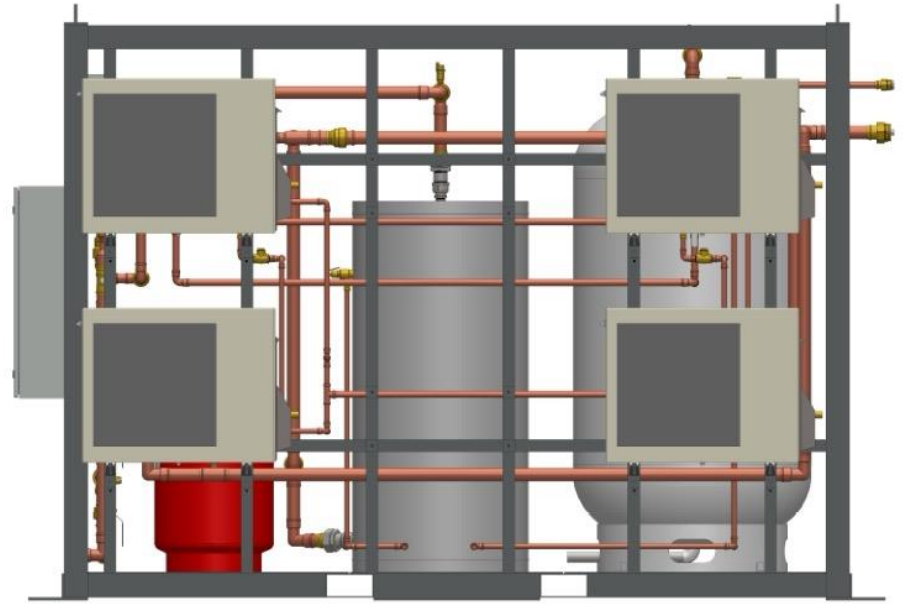
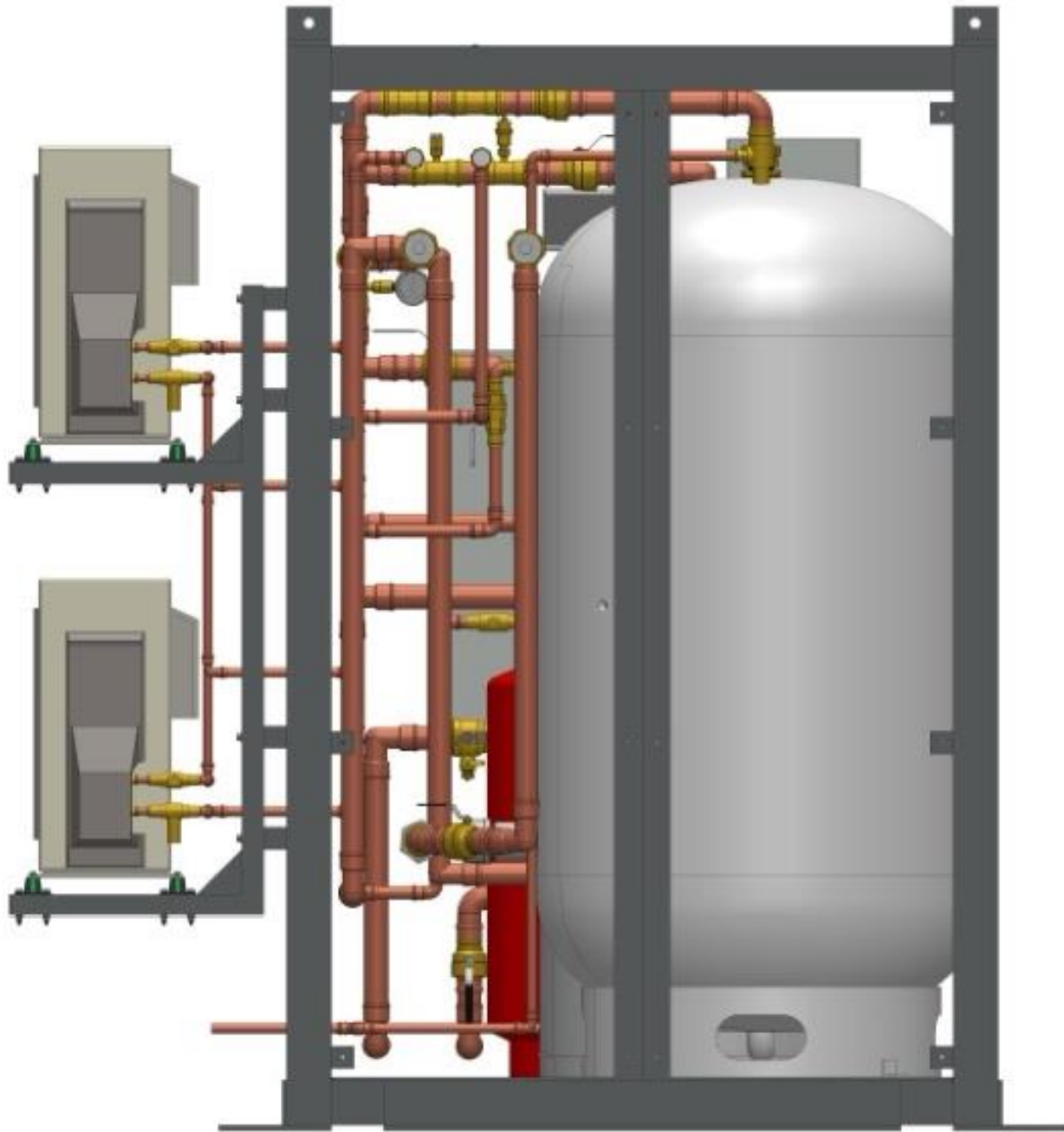

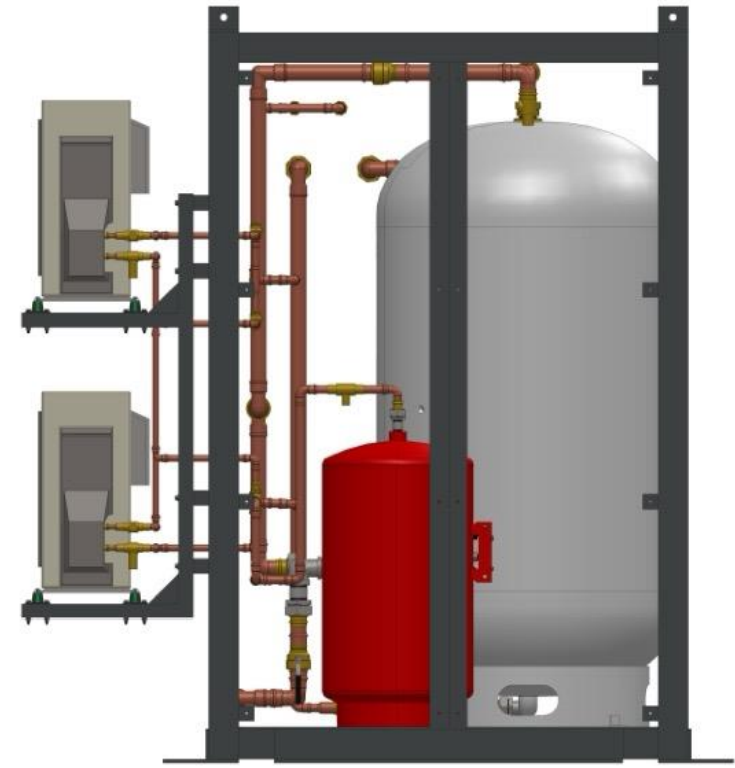
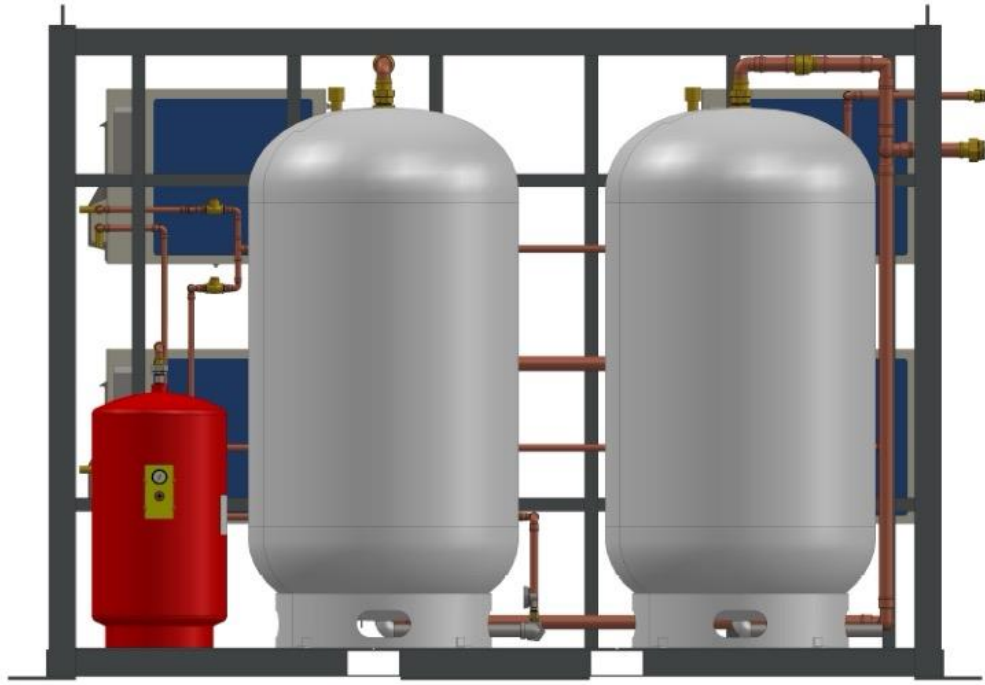

Extend the heat pumps and storage





Controller

R-8 Insulated Enclosure

Heat Pump

Electronic Mixing Valve

R-12 Primary Storage

9kw Swing Tank

Expansion

Recirc pump

BUILDING CONNECTIONS



Portal Project Menlo Park California

Multiple Plants, Each Serving a Zone, With Demand Response on Board





WATERDROP STANDARD SKID MODEL DATA

Model Number ¹	Pcs, Height	Total HPs	HP Recovery ²		Max Output ³ (Gal/Day)	Storage (Gallons)	Swing Tank (Gallons)	Swing Tank (kW)	Dimensions			Dry Weight (lbs)	Wet Weight (lbs)
			(kBtuh)	(Gal/Hr)					L (in)	W (in)	H (in)		
WD1S-30-0175-119-F-G-H-I-J-K	1 Piece, Std	2	31	37	592	175	119	6	149	94	101	4,800	7,500
WD1S-60-0300-119-F-G-H-I-J-K	1 Piece, Std	4	62	74	1,183	318	119	9	149	94	101	4,900	9,250
WD1S-75-0430-119-F-G-H-I-J-K	1 Piece, Std	5	77	92	1,479	432	119	9	149	94	101	5,250	10,400
WD1T-90-0500-119-F-G-H-I-J-K	1 Piece, Tall	6	92	111	1,775	500	119	12	149	94	123	5,350	11,000
WD2S-120-0650-119-F-G-H-I-J-K	2 Piece, Std	8	123	148	2,366	660	119	12	2 x 149	2 x 94	101	8,900	16,800
WD2S-150-0800-200-F-G-H-I-J-K	2 Piece, Std	10	154	185	2,958	795	200	18	2 x 149	2 x 94	101	9,500	19,300
WD2S-180-1000-200-F-G-H-I-J-K	2 Piece, Std	12	185	222	3,550	954	200	18	2 x 149	2 x 94	101	10,000	21,000

HP Capacity + Storage = Sizing

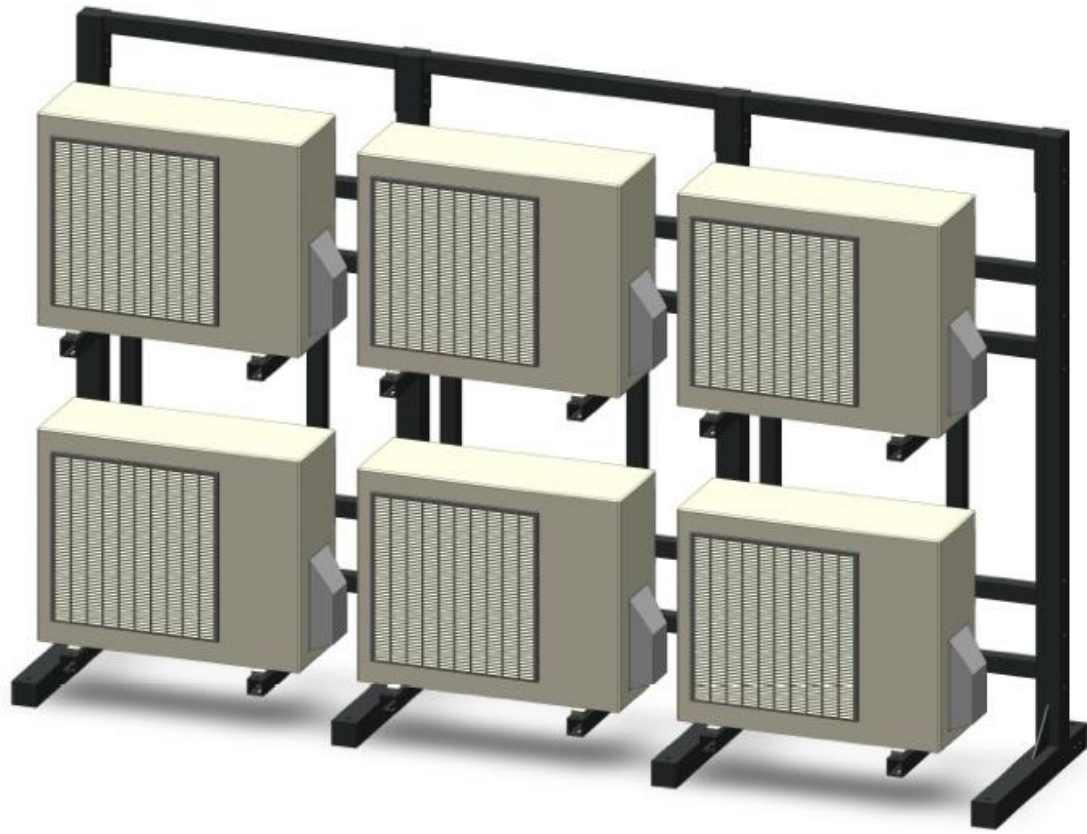

Droplet Racked Heat Pump Array

Heat pumps Outside – Tanks Inside

Available Droplet Configurations: 2/3/4/6/8/9/12

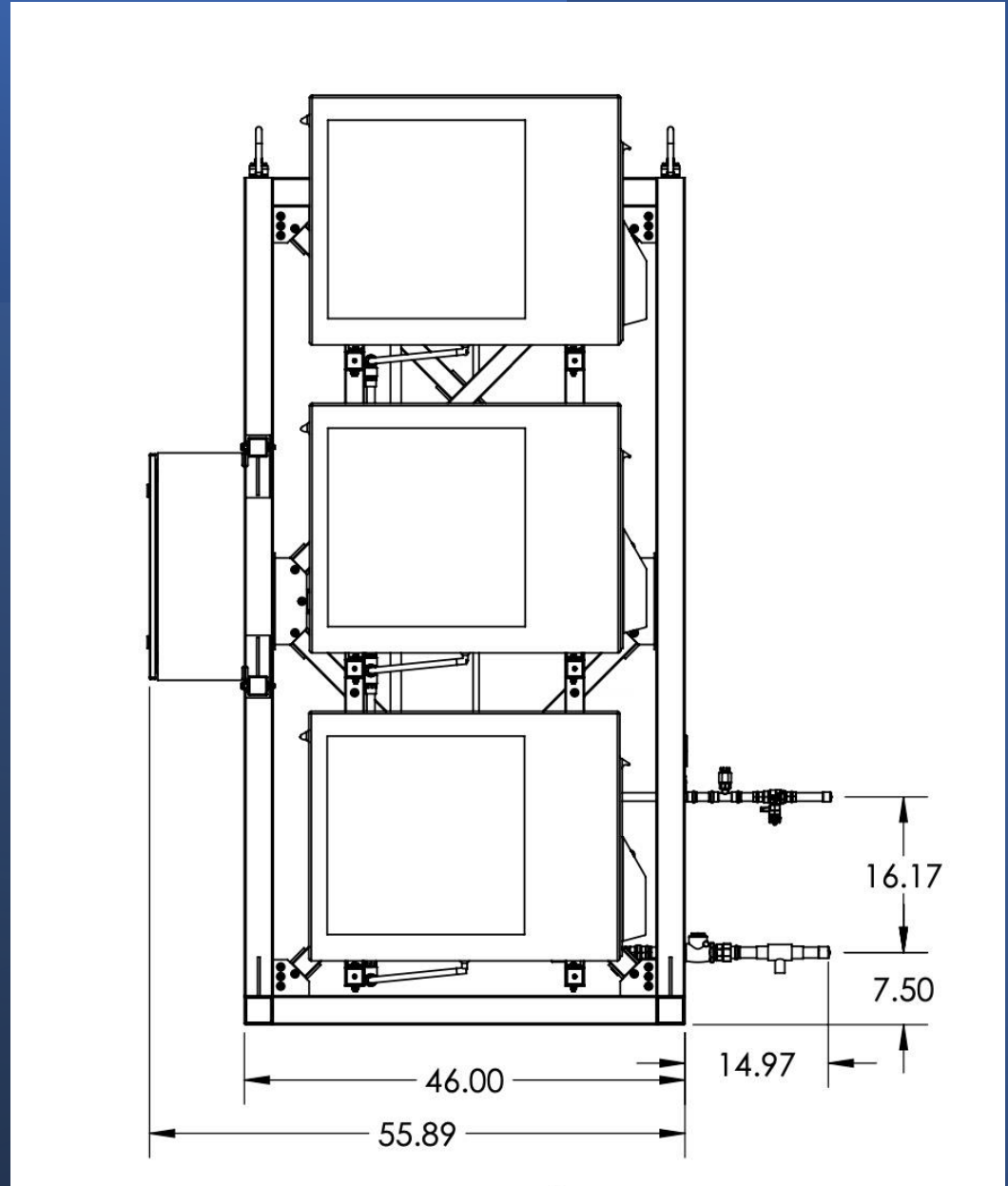
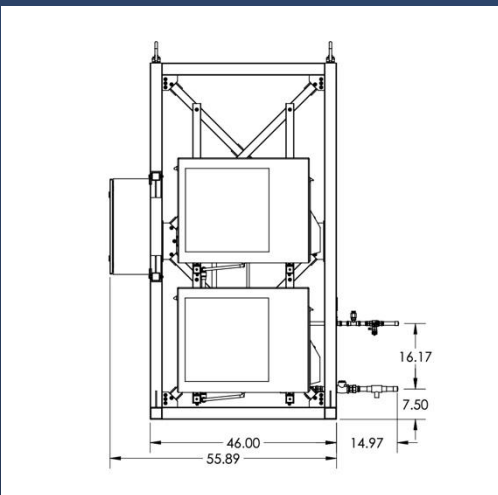
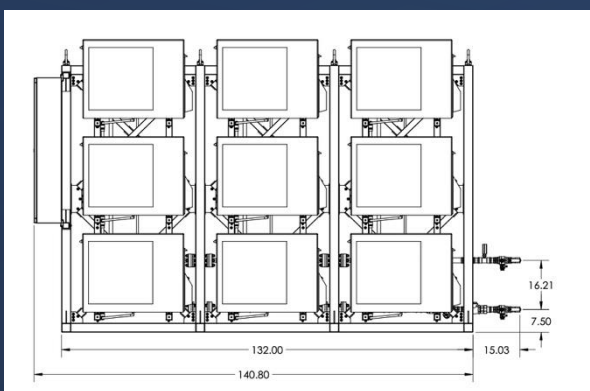
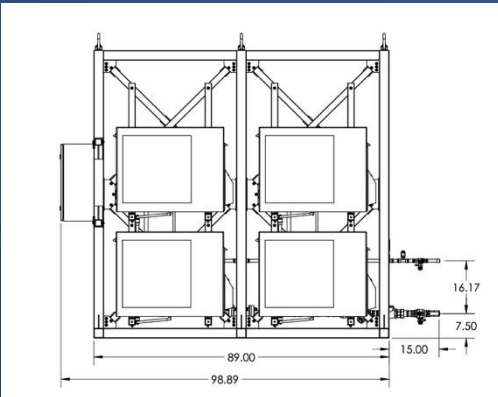
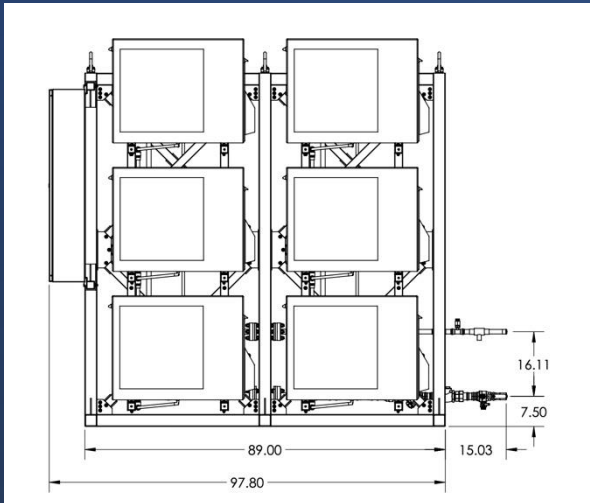
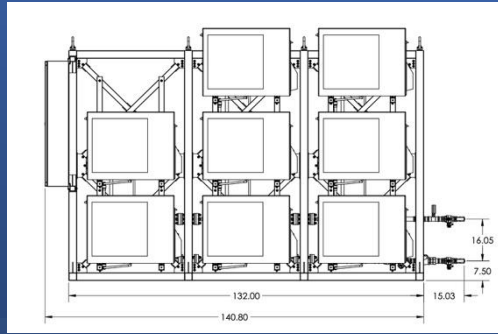
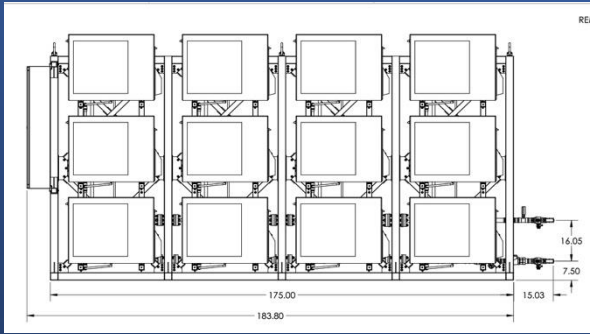



DROPLET HEAT PUMP RACK MODEL DATA

Model	Total HPs	HP Recovery ¹		Max Output ² (Gal/Day)	Dimensions ³			Dry Weight ³ (lbs)	Wet Weight ³ (lbs)
		(kBtuh)	(Gal/Hr)		L (ft)	W (ft)	H (ft)		
Droplet 2	2	31	37	592	60	45	80	400	550
Droplet 4	4	62	74	1,183	96	45	80	800	1,075
Droplet 6	6	92	111	1,775	135	45	80	1,200	1,600
Droplet 8	8	123	148	2,366	175	45	80	1,600	2,150
Droplet 10	10	154	185	2,958	135	90	80	2,150	2,850
Droplet 12	12	185	222	3,550	135	90	80	2,400	3,200



Big Buildings

Zone out and keep it tight

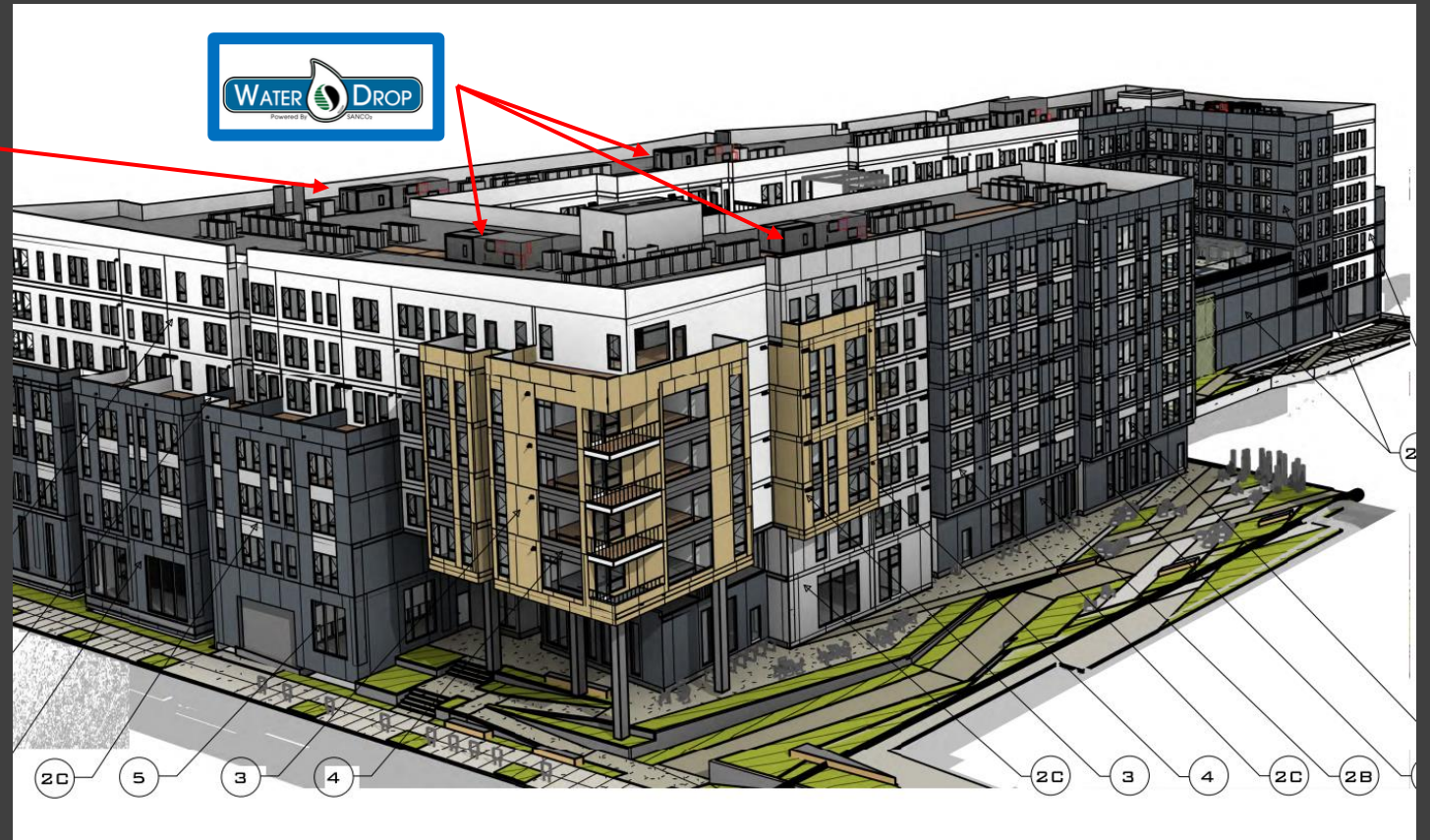
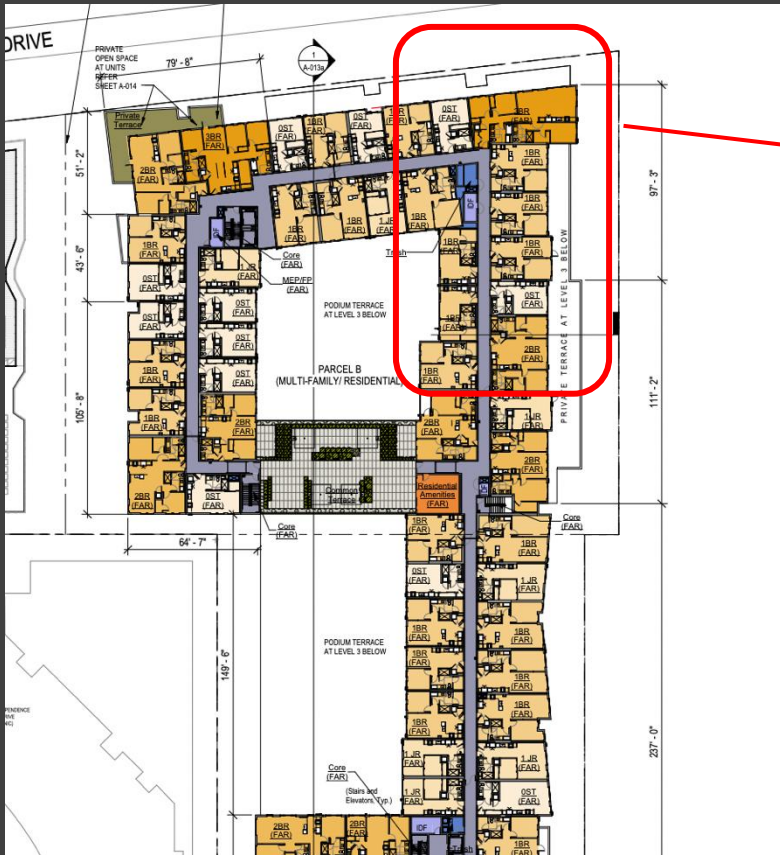

Break it into zones

- Compact distribution systems use less pump energy
- Shorter runs have less loss with a smaller swing tank lifts
- Multiple plants offer better security and lower power drops.



Questions?

(It's safe to to wake up now...)



Thanks for coming!

Continuing Education Units Available

- Contact itzel.torres@venturacounty.gov for any questions!

Today's Slides and Recording are Coming to Your Inbox Soon!

Upcoming Courses:

- Regional Forum: Retrofit Ready? Navigating the 2025 Energy Code for Aging Building (4/29)
- 2025 Energy Code in Practice: Multifamily Residential (5/13)
- Fire Resistant Homes: Smart Building Strategies for Risk Reduction and Energy Efficiency (5/14)
- Builder's Perspective: Insulation and Air Sealing (5/26)
- Home Improvements for a Healthier, Resilient, and Clean-Energy Future (5/27)

Any phone numbers who joined? Please share your name!

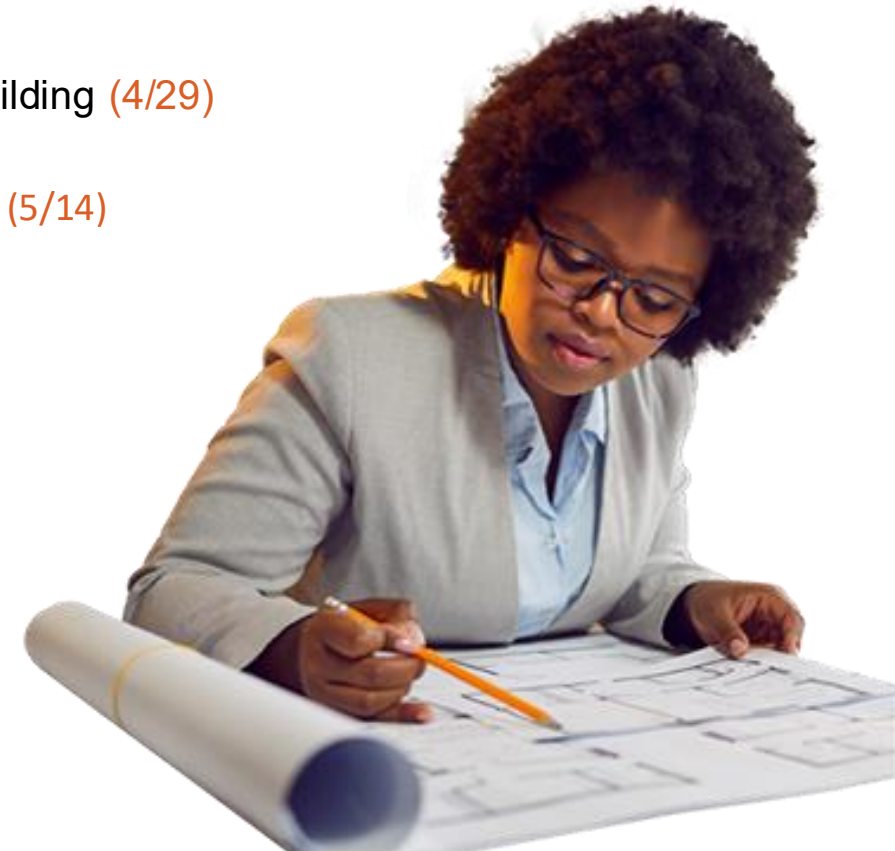

Thank you!

More info: **3c-ren.org**

Questions: **info@3c-ren.org**

Email updates: **3c-ren.org/newsletter**



TRI-COUNTY REGIONAL ENERGY NETWORK
SAN LUIS OBISPO • SANTA BARBARA • VENTURA

